

For Service Manuals
MAURITRON SERVICES
8 Cherry Tree Road, Chinnor
Oxfordshire, OX9 4QY.
Tel (01844) 351694
Fax (01844) 352554
email:- mauritron@dial.pipex.com

**WY-60
Maintenance
Manual**

WYSE

mP356

OVERVIEW

This maintenance manual contains information on how to service and repair the WY-60 terminal. We assume you are a qualified service technician with previous experience in terminal and computer repair. To take full advantage of this manual, we suggest you read the information in the order presented.

HOW TO USE THIS MANUAL

This manual is divided into seven chapters and four appendixes. The first chapter provides important information for the technician who has never serviced this terminal before. If you are already familiar with the terminal, the technical information in Appendix A can remind you about the terminal.

Here is a summary of this manual:

Chapter 1, "General Information," describes the terminal, including information about internal functions, input/output (I/O), telecommunications, environmental needs, and operator controls.

Chapter 2, "Removal and Replacement Procedures," shows you how to take the terminal apart and put it back together again.

Chapter 3, "Troubleshooting," tells you what to look for and how to fix problems with the terminal. It includes a list of tools needed for troubleshooting, a quick reference guide, and a flowchart.

Chapter 4, "Adjustments and Alignments," describes power supply and monitor adjustments that control the quality of the display.

Chapter 5, "Illustrated Parts List," includes a list of display and keyboard assembly parts.

Chapter 6, "Theory of Operations," describes the terminal operation by function.

Chapter 7, "Schematics and PCB Assembly Drawings," contains schematic representations of all the terminal's circuits.

Appendix A, "Specifications," lists the terminal's specifications.

Appendix B, "Connector Pin Assignments," lists the signals on each pin of the MODEM and the AUX ports located on the rear panel of the terminal.

Appendix C, "Test Connectors," describes how to make diagnostic hood test connectors.

Appendix D, "Display Inspection With the Reticle," describes how to check the terminal's display with a special tool, the reticle.

REFERENCE MANUALS

The following publications provide additional information about the terminal:

WY-60 User's Guide, Document 880259-02

WY-60 Programmer's Guide, Document 880261-01

TABLE OF CONTENTS

OVERVIEW	iii
1 GENERAL INFORMATION	
Introduction	1-1
High Level Functional Description	1-2
Microcontroller	1-2
Memory	1-2
Terminal Control	1-3
Input/Output Devices	1-3
Installation, Operation, and Care	1-4
2 REMOVAL AND REPLACEMENT PROCEDURES	
Overview	2-1
Removing and Replacing Assemblies in the Keyboard Modules	2-3
Removing and Replacing Assemblies in the Terminal Module	2-9
3 TROUBLESHOOTING	
Before You Start	3-1
Primary Troubleshooting Procedures	3-2
Troubleshooting Quick Reference Guide	3-4
Troubleshooting Flowchart	3-5
Additional Troubleshooting Procedures	3-12
4 ADJUSTMENTS AND ALIGNMENTS	
Before You Start	4-1
Checking Display Specifications	4-2
Aligning the Terminal Display	4-5
Adjusting the Terminal Display	4-10
Test Patterns	4-15

5 ILLUSTRATED PARTS LIST

Introduction	5-1
Printed Circuit Board Layout and Component Identification	5-2
Terminal Display Assembly Exploded View	5-3
Keyboard Assemblies Exploded Views	5-4
Terminal PCB Components List	5-6
Terminal Board Assembly Layout	5-13
WY-60 Full-Touch Keyboard PCB Components List	5-14
WY-60 Full-Touch Keyboard PCB Layout	5-14
316X-Style Keyboard PCB Components List	5-17
316X-Style Keyboard PCB Layout	5-17
AT-Style Keyboard PCB Components List	5-17
AT-Style Keyboard PCB Layout	5-17
Diagnostic Tools	5-20

6 THEORY OF OPERATIONS

Terminal PCB Logic Components Functional Description	6-1
Monitor/Power Supply Components Functional Description	6-6
Keyboard	6-8
Additional Functional Descriptions	6-9
Raster Scan Terminology	6-13

7 SCHEMATICS AND PCB ASSEMBLY DRAWINGS

Keyboard PCB Schematic, WY-60 ASCII	7-3
Keyboard PCB Schematic, AT-Style	7-5
Keyboard PCB Schematic, 316X-Style	7-7
Terminal PCB Schematic, Logic	7-9
Terminal PCB Schematic, Monitor/Power Supply	7-13
Keyboard PCB Assembly Drawing, WY-60 ASCII	7-15
Keyboard PCB Assembly Drawing, AT-Style	7-17
Keyboard PCB Assembly Drawing, 316X-Style	7-19
Terminal PCB Assembly Drawing	7-21

APPENDIXES

A Specifications	A-1
B Connector Pin Assignments	B-1
C Test Connectors	C-1
D Display Inspection with the Reticle	D-1

INDEX	I-1
-------------	-----

LIST OF FIGURES

1-1	Terminal Installed	1-4
1-2	User Controls	1-5
2-1	Terminal Modules	2-2
2-2	Keyboard Styles	2-3
2-3	ASCII Keyboard Assembly	2-5
2-4	316X- and AT-Style Keyboard Assembly	2-8
2-5	Removing the Terminal Enclosure	2-9
2-6	Replacing the Fuse	2-10
2-7	Removing the Terminal PCB	2-12
2-8	Removing the CRT/Yoke Assembly	2-14
2-9	Replacing the Yoke	2-15
2-10	Discharging the Anode Before Removal	2-17
2-11	Discharging the Anode Before Installation	2-18
3-1	Troubleshooting Flowchart	3-6
4-1	Power Supply Component Layout	4-8
4-2	Adjustment Locations	4-10
4-3	Yoke Lock on the CRT Neck	4-12
4-4	Centering Rings	4-13
4-5	Display Magnets	4-13
4-6	Pattern M	4-15
4-7	Pattern O	4-16
5-1	Sample PCB	5-2
5-2	Terminal Display Assembly Exploded View	5-3
5-3	Keyboard Assemblies Exploded Views	5-4
5-4	Terminal Board Assembly Layout	5-14
5-5	WY-60 ASCII Keyboard PCB Layout	5-16
5-6	316X-Style Keyboard PCB Layout	5-18
5-7	AT-Style Keyboard PCB Layout	5-20
6-1	Terminal PCB Logic Circuitry Functional Block Diagram	6-2
6-2	Monitor/Power Supply Circuitry Functional Block Diagram	6-7
6-3	Keyboard Block Diagram	6-8
7-1	WY-60 ASCII Keyboard PCB Schematic	7-3
7-2	AT-Style Keyboard PCB Schematic	7-5
7-3	316X-Style Keyboard PCB Schematic	7-7
7-4	Terminal PCB Schematic (Logic)	7-9
7-4	Terminal PCB Schematic (Monitor/Power Supply)	7-13
7-5	WY-60 ASCII Keyboard PCB Assembly Drawing	7-15
7-6	AT-Style Keyboard PCB Assembly Drawing	7-16
7-7	316X-Style Keyboard PCB Assembly Drawing	7-17
7-8	Terminal PCB Logic Assembly Drawing	7-18

LIST OF FIGURES, Continued

B-1	Pin Numbers (MODEM and AUX Ports)	B-1
D-1	Video Inspection Reticle	D-1
D-2	Checking Width and Height	D-3
D-3	Checking Straightness, Pincushioning, Centering, and Vertical Linearity	D-4

LIST OF TABLES

3-1	Module Level Troubleshooting Quick Reference Guide	3-5
3-2	Terminal Installation Checklist	3-13
3-3	Terminal PCB Circuit Isolation Jumpers	3-16
4-1	Display Problems and Their Adjustments	4-9
4-2	Screen Areas Affected by Display Magnets	4-14
5-1	Reference Designator Letters	5-2
5-2	Terminal PCB Components List	5-7
5-3	WY-60 ASCII Keyboard PCB Components List	5-15
5-4	316X-Style Keyboard PCB Components List	5-17
5-5	AT-Style Keyboard PCB Components List	5-19
5-6	Diagnostic Self-Test Connectors	5-21
6-1	Clock Rates	6-4
6-2	8051 Port Assignments	6-9
B-1	MODEM Port Connector Pin Assignments (DTE)	B-1
B-2	Typical Modem Pin Assignments	B-2
B-3	AUX Port Connector Pin Assignments (DCE)	B-2

1 GENERAL INFORMATION

Introduction	1-1
High Level Functional Description	1-2
Microcontroller	1-2
Memory	1-2
Terminal Control	1-3
Input/Output Devices	1-3
CRT Display	1-3
Communications Interfaces	1-3
Keyboard	1-3
Installation, Operation, and Care	1-4
Installation	1-4
Operation	1-5
Care	1-6

INTRODUCTION

This versatile, full-function ASCII terminal includes the following features:

- o Choice of three different keyboards
- o Up to seven pages of display memory
- o Choice of 26- or 44-line by 80- or 132-column display, with split screen capability and selectable status lines
- o Hidden character display attributes that can be combined with double-high/double-wide line attributes; nonhidden attribute modes
- o Seven predefined character sets and 512 user-definable characters
- o Fifteen operating modes with personalities characteristic of other terminals, including PC and PC/AT terminal modes
- o Bidirectional, interchangeable communications interfaces

- o WyseWorks desktop accessories
- o Wyseword WordStar key definitions

The terminal consists of a display console and a detachable keyboard. A user enters information for display from the keyboard. The terminal contains all of the electronics that support the display and keyboard.

In addition to the cathode ray tube (CRT) and keyboard, the terminal contains two independent communications interfaces. Peripherals, including a hard-copy printer or plotter, can be attached to the terminal through the interface connectors on the rear panel.

The component parts are organized around and controlled by the microcontroller. The microcontroller controls all internal data manipulation and processing functions.

HIGH LEVEL FUNCTIONAL DESCRIPTION

The terminal consists of a microcontroller and related logic, a CRT controller and associated control logic, a gate array, input/output (I/O) devices, monitor and power supply circuitry, and a CRT. All circuitry is mounted on a single printed circuit board (PCB), the terminal PCB. The microcontroller controls all basic functions.

MICROCONTROLLER

The heart of the terminal, the 8051 microcontroller, is an 8-bit, single-component microcontroller that has 128 bytes of random access memory (RAM), 32 I/O lines, three 16-bit counter/timers, a full-duplex universal asynchronous receiver/transmitter (UART), and integral interrupt and clock circuitry.

MEMORY

The terminal memory consists of EEPROM, RAM, EPROM, and ROM. The terminal EEPROM is the X2404, which stores all user selected setup parameters. Terminal RAM includes the Character RAM, the Attribute RAM, and the Font RAM. In hidden attribute mode, the Character RAM holds a character for each character cell on the screen. The Attribute RAM holds an attribute for each character cell on the screen. The Font RAM holds four predefined character sets and that may include additional user-defined characters. Terminal ROM includes the Code ROM, which holds the program code that operates the terminal, and the ROM internal to the 8051 that supports the Code ROM.

TERMINAL CONTROL

Terminal control components include the 8051 microcontroller described above and the 2672 programmable video timing controller (PVTC). The 2672 controls vertical and horizontal timing, consecutive addressing for the display memory, the microcontroller-display buffer interface, and consecutive addressing of row buffers. The PVCT controller reads displayed characters and attributes from their respective RAMs on a DMA basis, sending this information to the gate array. The gate array generates the video signals that control the display.

Functions of the terminal firmware include keyboard scanning, programming the video controller, data transfer to and from the communication ports, and data manipulation.

INPUT/OUTPUT DEVICES

I/O devices consist of a CRT display, two communications interfaces, and a keyboard.

CRT Display

The terminal has a 14-inch, flat-screen CRT. It displays 26 or 44 rows of characters and 80 or 132 columns. Available phosphor colors for the CRT include green, amber, and white.

Communications Interfaces

The terminal has two asynchronous serial interfaces that conform with the EIA standard RS-232C. Data rates are set independently for both interfaces. These parameters are operator controlled and are defined in "Setup Parameters" in the User's Guide. The MODEM interface can communicate at data rates up to 38.4K bits per second (bps). The AUX interface can communicate at data rates up to 19.2K bps.

Keyboard

The terminal is available with three keyboards: the WY-60 ASCII keyboard, an 316X-style keyboard, and an AT-style keyboard. Each has a standard four-wire interface with the terminal. All keys are momentary action key switches. The microprocessor periodically scans the keys, checking for key closures.

Figure 2-2 in Chapter 2 shows the keyboards. You can find additional information about the keyboards in Chapter 6, "Theory of Operations" and Chapter 7, "Schematics."

INSTALLATION, OPERATION, AND CARE

Some problems you may see can be caused when users don't install, operate, or care for the terminal correctly. The following paragraphs are a quick overview discussing correct installation, operation, and care.

Installation

Correct installation meets the following requirements:

- o Terminal rests on a horizontal, vibration-free surface.
- o Screen avoids direct sunlight.
- o Room lighting is not abnormally bright.
- o Terminal is located away from strong magnetic fields.
- o Room temperature never exceeds 45 degrees Celsius (113 degrees F).
- o Terminal location allows three inches clearance around and above the terminal.
- o Keyboard is correctly connected in keyboard socket.
- o RS-232C communication cable is correctly connected to the terminal and the computer.
- o Power cord is correctly connected to the terminal and a power source.

Figure 1-2 shows the correct terminal connections.

Figure 1-2 Terminal Installed

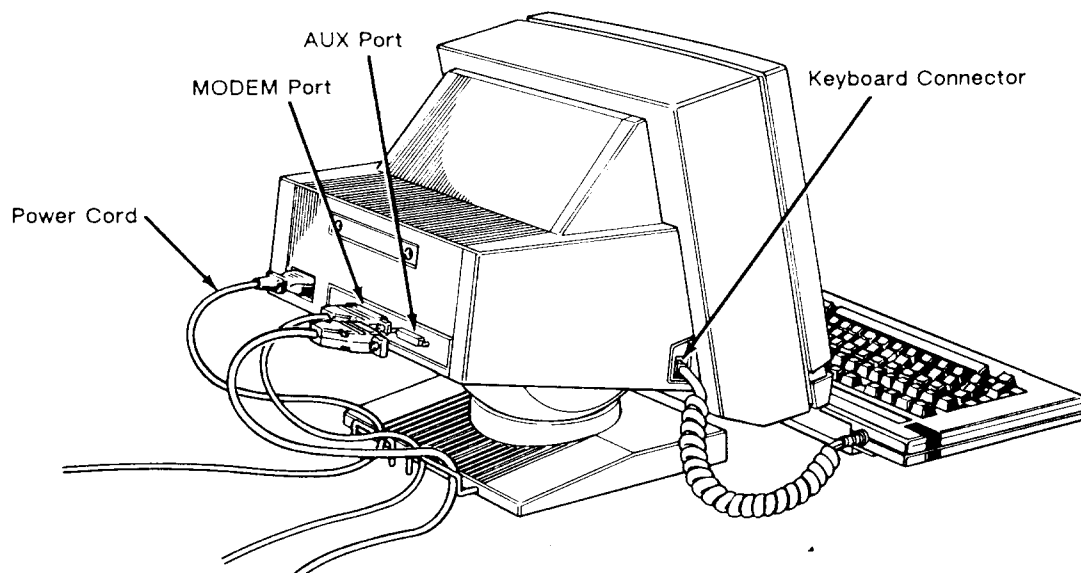

Operation

Two areas of operation are important to understand: user controls and setup.

User controls--Figure 1-3 shows three user controls: the power switch, brightness slideswitch, and the keyboard.

Figure 1-3 User Controls

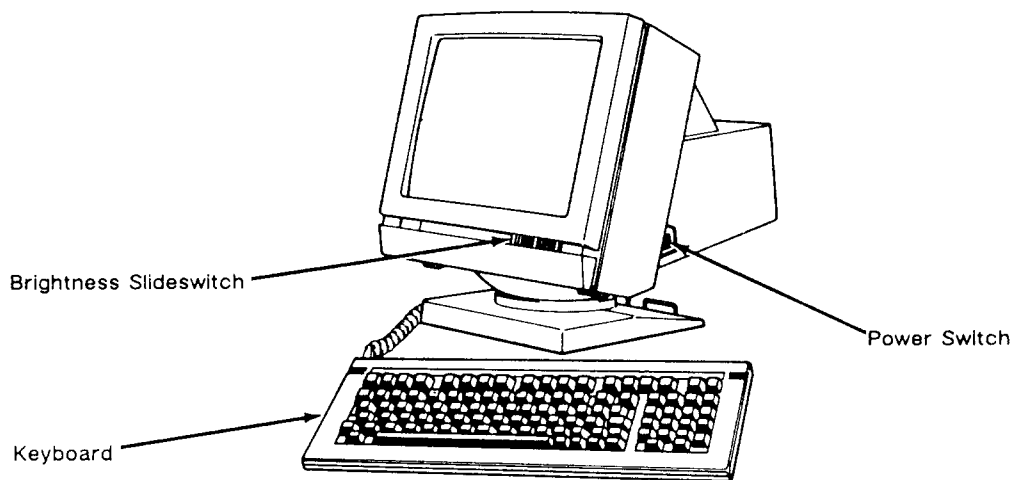

The power switch is on the right side of the terminal. Pressing the back of the switch turns AC power on.

The brightness slideswitch is located on the lower-right corner of the front bezel. Sliding the switch to the right increases the display brightness; sliding it to the left decreases the brightness.

Plugging the keyboard cable connector into the keyboard connector jack on the left side of the terminal enables the user to control the display with the keyboard.

SetUp--When a user turns the power on, the terminal executes an internal self-test. When the self-test finishes and the CRT is warm (approximately 30 seconds), the cursor appears in the upper left-hand corner of the display. The user can operate the terminal or enter setup mode to change certain operating values based on the parameters controlled in setup.

To check the parameters, press both the SHIFT and SETUP keys. The first level of parameters appears across the bottom of the screen. To examine the other parameter menus, press function keys F1 through F10. Each time you press a different key, you can see a different menu.

To change the parameters, follow these steps:

1. Enter setup mode by pressing the SHIFT and SETUP keys. (Press the SHIFT and SYS REQ keys on the AT-style keyboard.)
2. Press one of the designated function keys (F1 through F10). The menu assigned to that function key will appear on the screen.
3. Press the cursor keys until the specific parameter to be changed is highlighted.
4. Press the SPACEBAR to advance the parameter to the specific setting desired.
5. Press the cursor keys as required to advance to the next parameter to be changed.
6. To leave setup mode, either press the SHIFT and SETUP keys or the F10 key. In all levels other than the top setup level, you must press these keys twice.

The terminal is now operational using the parameters defined in the setup mode.

See the WY-60 User's Guide for more comprehensive setup instructions.

CARE

You may find that the terminal needs to be cleaned when you've finish servicing it. The screen should be cleaned with a soft, lint-free cloth. Apply a safe cleaner to the cloth, not directly to the screen.

Caution--Don't ever clean the screen with chemical substances, abrasives, or commercial glass cleaners that contain alcohol.

2 REMOVAL AND REPLACEMENT PROCEDURES

Overview	2-1
Safety	2-2
Required Tools	2-3
Removing and Replacing Assemblies in the Keyboard Modules	2-3
ASCII Keyboard Replacement	2-4
ASCII Keyboard Cable Replacement	2-5
ASCII Keyboard PCB Replacement	2-6
316X- and AT-Style Keyboard Replacement	2-7
316X- and AT-Style Keyboard Cable Replacement	2-7
316X- and AT-Style Keyboard PCB Replacement	2-7
Removing and Replacing Assemblies in the Terminal Module	2-9
Removing the Terminal Enclosure	2-9
Replacing the Fuse	2-10
Removinnng and Replacing the Terminal PCB	2-11
Removing and Replacing the CRT/Yoke Assembly	2-13
Removing and Replacing the Yoke	2-15
Replacing the Terminal Enclosure	2-16
Discharging the Anode	2-16

OVERVIEW

This chapter explains how to remove and replace assemblies and components in both terminal modules. For purposes of orientation, "front" is the monitor face, and "back" is the rear panel and power cord location.

The terminal consists of two major modules (see Figure 2-1):

- o Terminal The terminal module includes the CRT/yoke assembly and the terminal PCB. The terminal PCB holds all control logic, power supply circuitry, and the circuitry to amplify and display horizontal, vertical, and video signals on the CRT screen.

- o Keyboard The keyboard module includes the keyboard PCB and the keyboard cable.

Figure 2-1 Terminal Modules

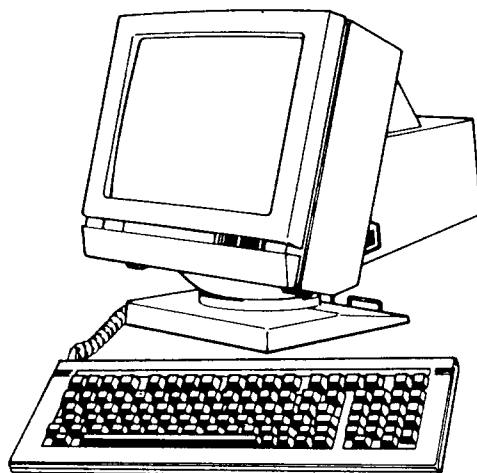

Safety

Warning--This terminal contains high voltage. Don't attempt to service the terminal without taking all the precautions necessary to work with high voltage, including the following:

- o If you must open the terminal for any reason, turn off the power, disconnect any communications cables, and unplug the terminal.
- o Remove any jewelry, especially on hands and wrists.
- o Avoid wearing clothing that holds a static charge.
- o Use only insulated or nonconductive tools.
- o Whenever you disconnect the anode lead from the anode, make sure to ground the anode as directed in "Discharging the Anode."
- o If you need to remove or replace the CRT/yoke assembly, remember that it can implode if you drop it or break the neck. The flying glass can injure anyone within a radius of six to ten feet.

Required Tools

Before you remove or replace any assemblies in the terminal, make sure you have the tools and materials listed below.

- o No. 0 Phillips screwdriver
- o No. 2 Phillips screwdriver
- o Insulated flat-blade screwdriver
- o Alligator clips
- o Digital multimeter (or voltmeter)
- o Nonscratch mat or surface
- o Fuse puller or small flat-blade screwdriver

REMOVING AND REPLACING ASSEMBLIES IN THE KEYBOARD MODULES

The terminal has three keyboard options: the WY-60 ASCII keyboard, the 316X-style keyboard, and the AT-style keyboard. See Figure 2-2 if you need to identify your keyboard. Removal and replacement instructions for the ASCII keyboard are first, followed by another set of instructions for the other keyboard styles. Each set of instructions describes procedures to remove and replace the keyboard, keyboard cable, and keyboard PCB.

Figure 2-2 Keyboard Styles

WY-60 ASCII Keyboard Layout

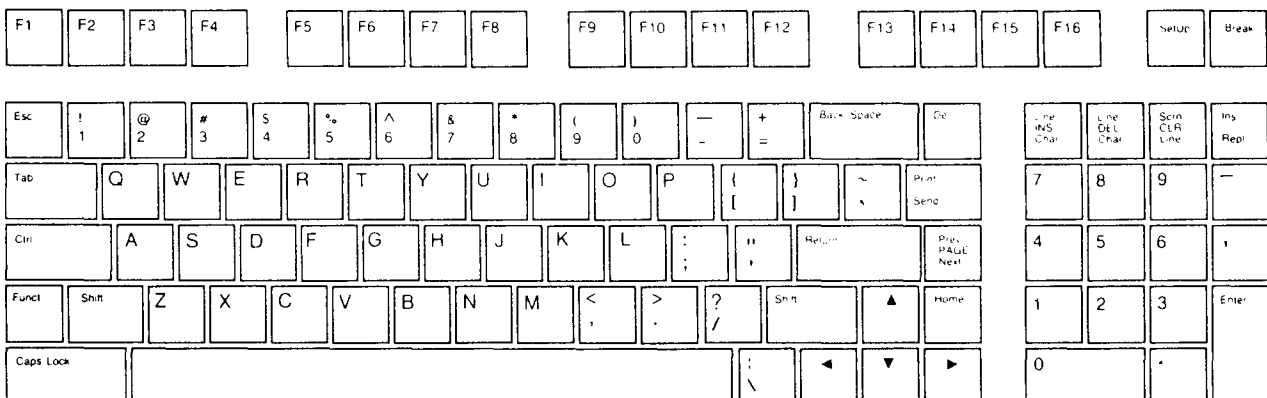

3161X-Style Keyboard Layout

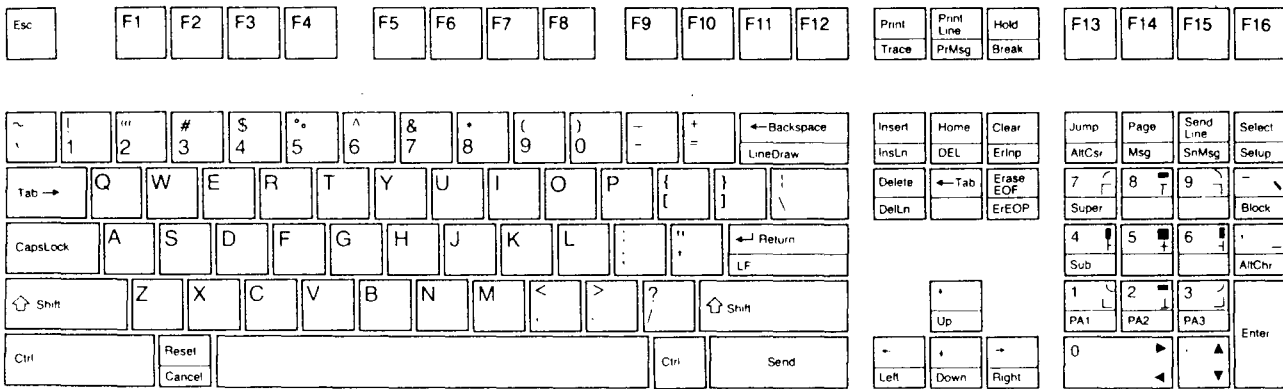

AT-Style Keyboard Layout

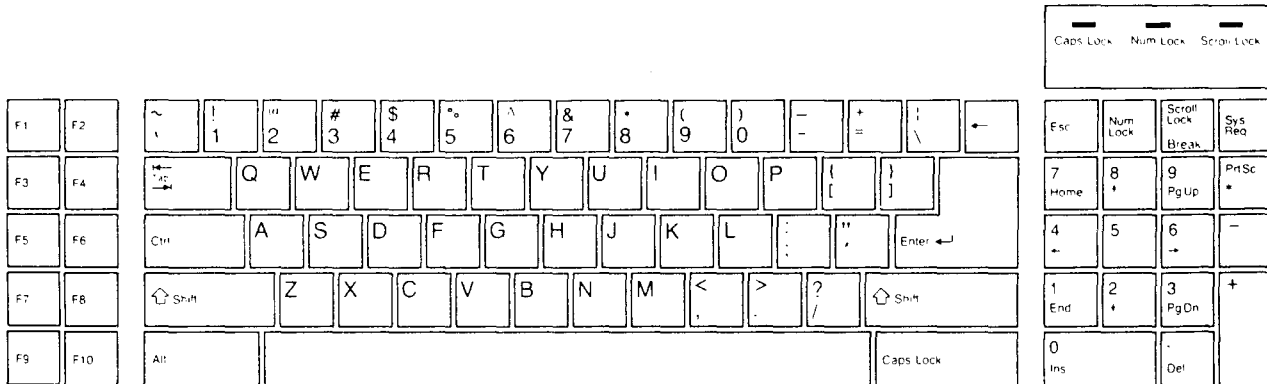

ASCII Keyboard Replacement

Tools required: None

Follow these steps to replace the keyboard (see Figure 2-3):

1. Turn the terminal off.
2. Press the keyboard cable connector tab and pull the keyboard cable out of the keyboard socket on the side of the terminal.
3. Plug the new keyboard into the terminal keyboard socket.

Figure 2-3 ASCII Keyboard Assembly

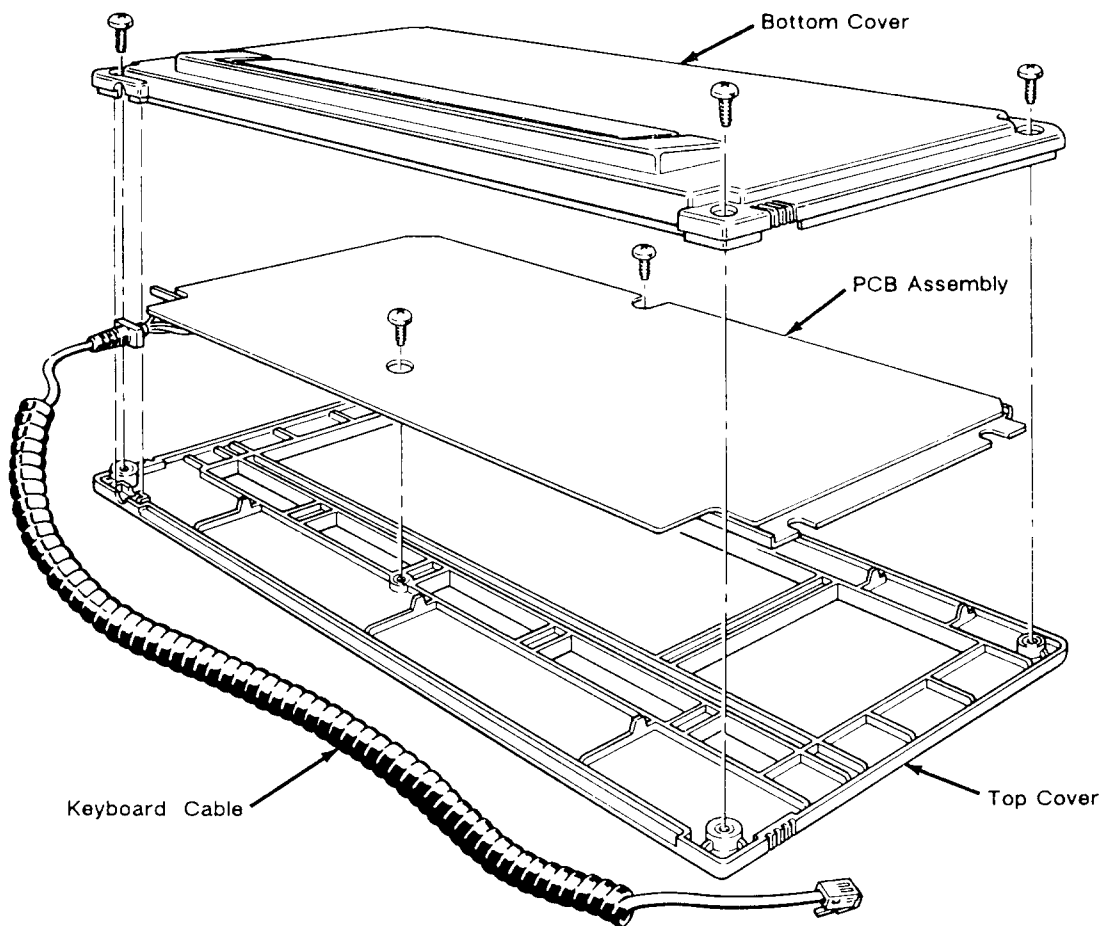

ASCII Keyboard Cable Replacement

Tools required:

- o No. 2 Phillips screwdriver

To replace the keyboard cable (see Figure 2-3):

1. Turn the terminal off.
2. Press the keyboard cable connector tab and pull the cable out of the keyboard socket on the side of the terminal.
3. Unscrew the four Phillips screws on the bottom of the keyboard. Remove the bottom cover.
4. Unscrew the two Phillips screws on the bottom of the exposed keyboard PCB, holding the PCB to the top cover.

For Service Manuals
MAURITRON SERVICES
8 Cherry Tree Road, Chinnor
Oxfordshire, OX9 4QY.
Tel (01844) 351694
Fax (01844) 352554
email:- mauritron@dial.pipex.com

5. Lift the keyboard PCB out of the top cover. Turn it over.
6. Disconnect the keyboard cable from the keyboard cable connector on the PCB.
7. Connect the new keyboard cable at the keyboard cable connector on the keyboard PCB.
8. Fit the keyboard PCB into the top cover, making sure to fit the keyboard cable into its special slot. Replace the screws that secure the PCB to the top cover.
9. Replace the bottom cover and screws.
10. Plug the free end of the keyboard cable into the terminal keyboard socket.

ASCII Keyboard PCB Replacement

Tools required:

- o No. 2 Phillips screwdriver

To replace the keyboard PCB (see Figure 2-3):

1. Turn the terminal off.
2. Press the keyboard cable connector tab and pull the keyboard cable out of the keyboard socket on the side of the terminal.
3. Unscrew the four Phillips screws on the bottom of the keyboard. Remove the bottom cover.
4. Unscrew the two Phillips screws on the bottom of the exposed keyboard PCB, holding the PCB to the top cover.
5. Lift the keyboard PCB out of the top cover. Turn it over.
6. Disconnect the keyboard cable connector J1 from the keyboard PCB.
7. Reconnect the keyboard cable connector at J1 on the new keyboard PCB.
8. Fit the keyboard PCB into the top cover, making sure to fit the keyboard cable into its special slot. Replace the screws that secure the PCB to the top cover.
9. Replace the bottom cover and screws.
10. Plug the free end of the keyboard cable into the terminal keyboard socket.

316X- and AT-Style Keyboard Replacement

Tools required: None

To replace the keyboard (see Figure 2-4), follow these steps:

1. Turn off the terminal.
2. Press the keyboard cable connector tab and pull the keyboard cable out of the keyboard.
3. Plug the keyboard cable into the new keyboard's connector.

316X- and AT-Style Keyboard Cable Replacement

Tools required: None

To replace the keyboard cable (see Figure 2-4), follow these steps:

1. Turn the terminal off.
2. Press the keyboard cable connector tab and pull the keyboard cable out of the keyboard.
3. Press the other keyboard cable connector tab and pull the keyboard cable out of the left side of the terminal.
4. Insert one end of the new keyboard cable into the keyboard connector. Insert the other end into the terminal keyboard socket.

316X- and AT-Style Keyboard PCB Replacement

Tools required:

- o No. 0 Phillips screwdriver
- o No. 2 Phillips screwdriver

To replace the keyboard PCB (see Figure 2-4), follow these steps:

1. Turn off the terminal.
2. Unplug the keyboard cable from the keyboard.
3. Turn the keyboard over and remove the six No. 2 Phillips screws that attach the keyboard bottom cover to the keyboard.
4. Lift off the keyboard bottom cover.

Figure 2-4 316X- and AT-Style Keyboard Assembly

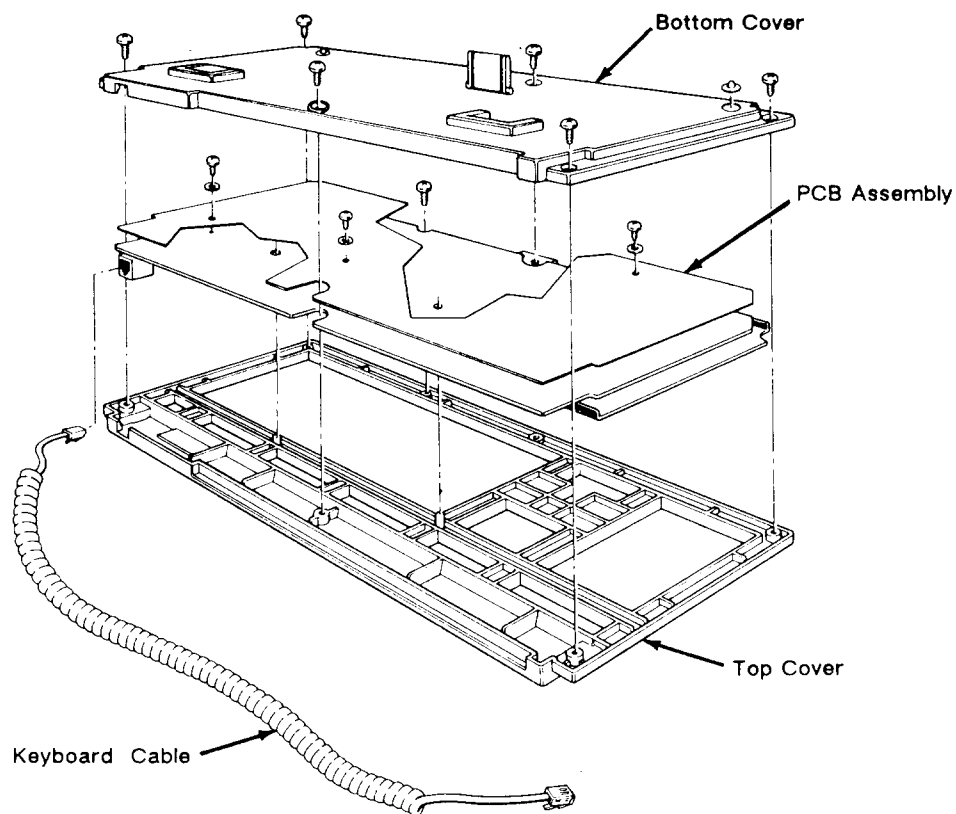

5. Remove the No. 0 Phillips screw beneath the SPACEBAR that holds the keyboard top cover to the PCB assembly.
6. Unscrew the three No. 0 Phillips screws and washers that hold the keyboard ESD shield on the keyboard PCB.
7. Lift the PCB assembly out of the keyboard cover.
8. Cover the under side of the new keyboard PCB with the keyboard ESD shield. Replace the screws and washers. Tighten.
9. Fit the new keyboard PCB assembly back into the keyboard top cover.
10. Replace the No. 0 Phillips screw that holds the PCB assembly in place.
11. Reattach the bottom cover of the keyboard assembly.
12. Plug the keyboard cable back into the terminal.

REMOVING AND REPLACING ASSEMBLIES IN THE TERMINAL MODULE

This section describes removing and replacing the terminal enclosure, the fuse, the terminal PCB, and the CRT/yoke assembly. It also describes how to discharge the CRT anode.

Removing the Terminal Enclosure

Tool required:

- o No. 2 Phillips screwdriver

To remove the terminal enclosure (see Figure 2-5), follow these steps:

1. Remove all cables and power cords from the rear of the terminal.
2. Rest the display face of the terminal on a nonscratch surface.

Figure 2-5 Removing the Terminal Enclosure

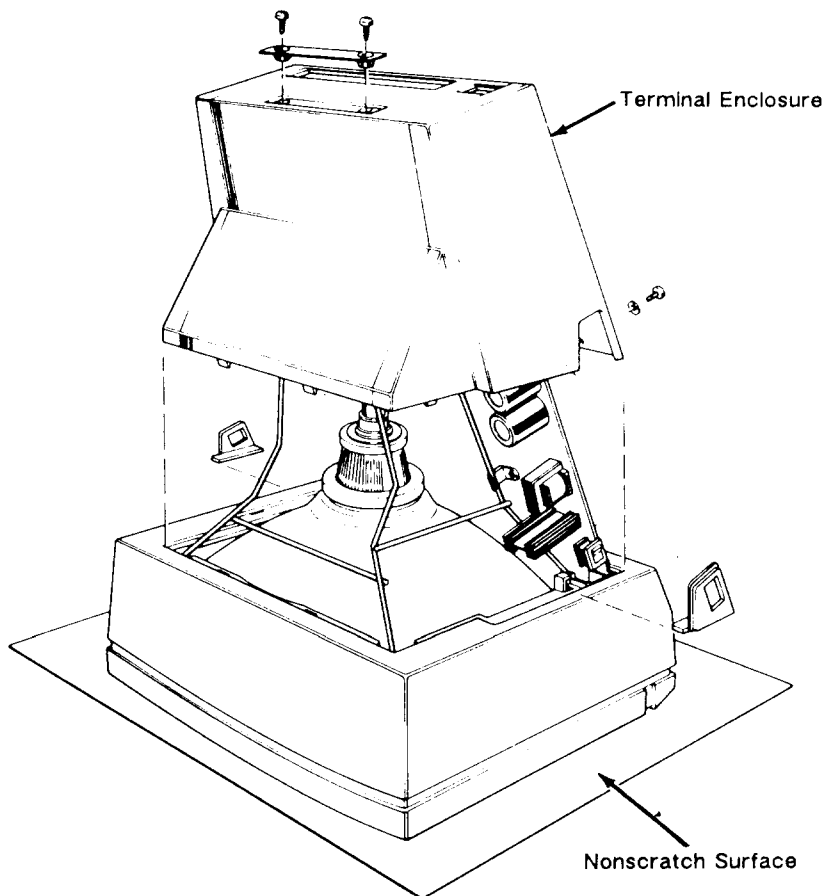

3. Disconnect the keyboard cable on the left side of the terminal enclosure.
4. Remove the two No. 2 Phillips screws from the rear panel of the terminal enclosure.
5. Remove the two No. 2 Phillips screws from the bottom of the terminal enclosure, next to the back bezel.
6. Lift off the terminal enclosure.

Replacing the Fuse

Tool required:

- o Fuse puller or screwdriver

The terminal has a BEL5MT2 fuse, rated 2 amps, 125 volts (international rating is 1.6 amps, 250 volts). See Figure 2-6 for the fuse location on the terminal PCB.

To check or replace the fuse, follow these steps:

1. Remove the terminal enclosure. See Figure 2-5.
2. Use a fuse puller to remove the fuse.

Figure 2-6 Replacing the Fuse

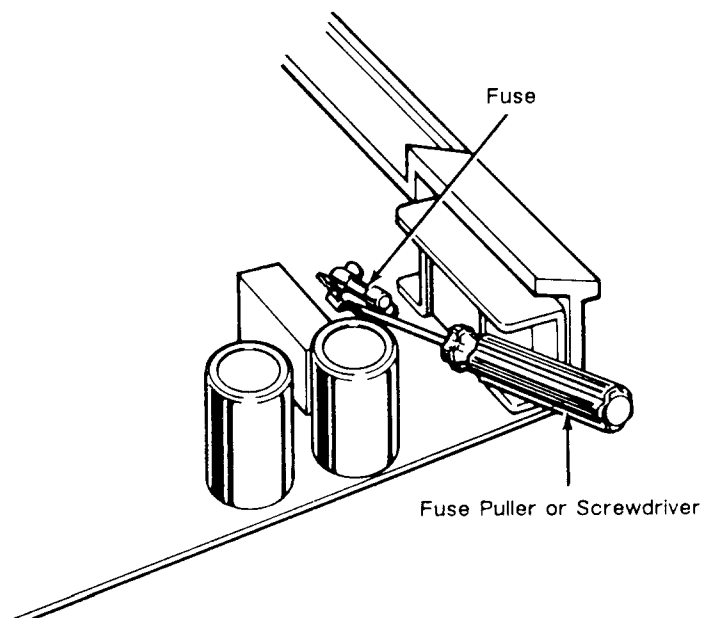

3. Check the fuse. If the fuse is broken or blackened, push a new fuse into the fuse socket.

If the fuse is good, push it back into the fuse socket.

4. Replace the terminal enclosure (see "Replacing the Terminal Enclosure" for instructions).

Removing and Replacing the Terminal PCB

Tools required:

- o No. 2 Phillips screwdriver
- o Flat-bladed screwdriver
- o Alligator clips

To remove the terminal PCB (see Figure 2-7), follow these steps:

1. Unplug the terminal and remove the shielded RS-232 communication cable.
2. Remove the terminal enclosure.
3. Slide the barrier plates mounted on either side of the back bezel out from under the restraining tabs.
4. Leaving the terminal on its face, pull the back bezel off the terminal frame.
5. Discharge the anode (see "Discharging the Anode" for instructions).
6. Disconnect the anode lead.
7. Disconnect the yoke harness connector, P201, from the terminal PCB.

Warning--Handle the CRT neck carefully. If you break it, flying glass can injure anyone within a radius of six to ten feet.

8. Disconnect the tube socket from the neck of the CRT.
9. Unscrew the two Phillips No. 2 screws that secure the grounding wires to the CRT wire frame.

Caution--Don't remove the Phillips screws directly underneath the rear panel on the terminal PCB. They fasten the rear panel to the terminal PCB.

10. Remove the four plastic studs that secure the ESD shield to the back of the terminal PCB.

11. Loosen the three screws that hold the ESD shield in place.
12. Remove the ESD shield.
13. Loosen the remaining three No. 2 Phillips screws on the underside of the terminal PCB.
14. Lift the terminal PCB up and out.

Figure 2-7 Removing the Terminal PCB

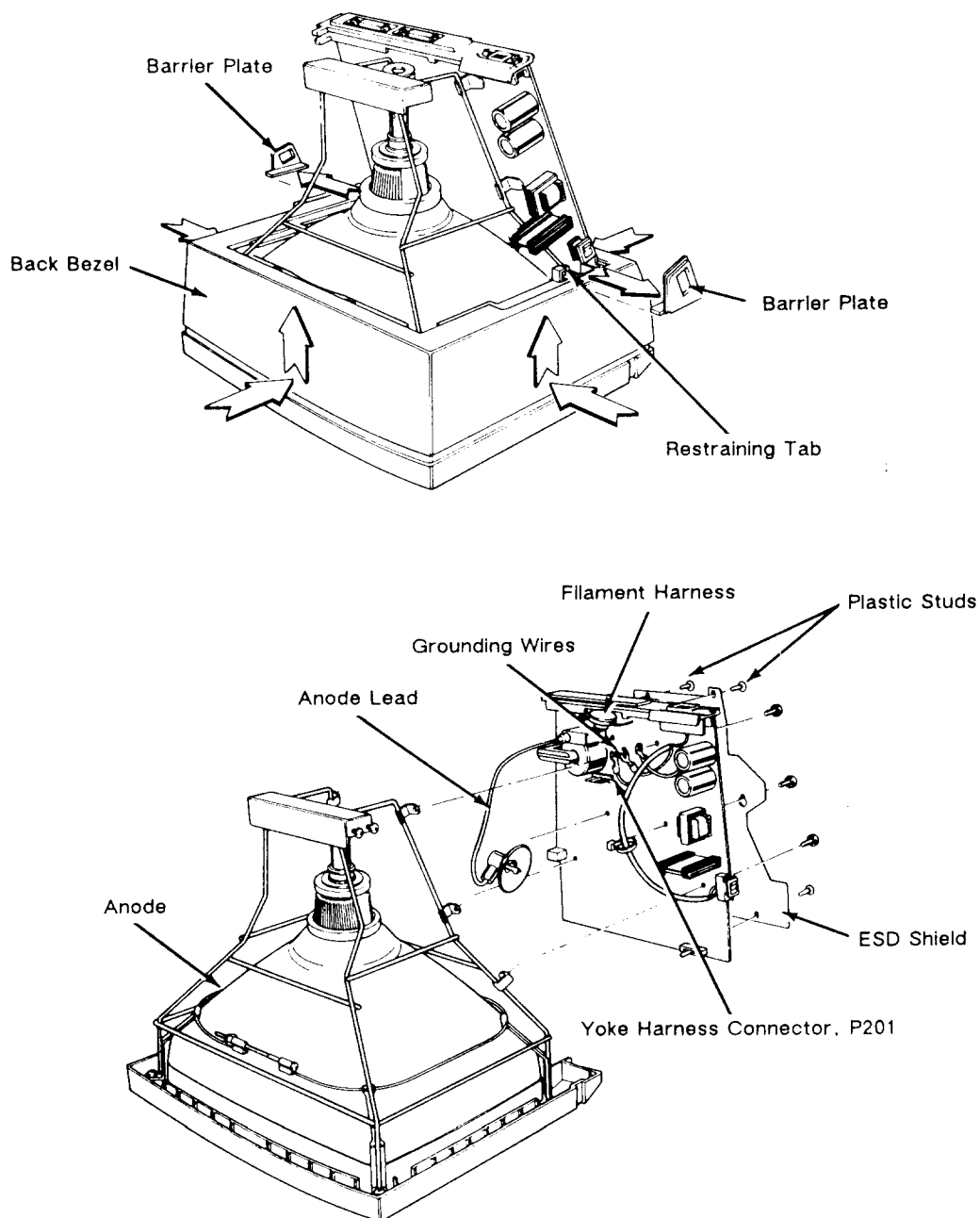

To replace the terminal PCB, follow these steps:

1. Position the ESD shield on the back of the terminal PCB.
2. Replace the four plastic studs that secure it.
3. Position the terminal PCB in its slot in the bezel. Make sure the lever of the brightness potentiometer fits into the brightness slidecontrol on the bezel.
4. Tighten the three screws that secure the terminal PCB to the wire frame.
5. Replace the ESD shield, then tighten the three remaining screws.
6. Reconnect the grounding wires to the wire frame.
7. Reconnect the yoke harness to P201 on the terminal PCB.

Warning--Handle the CRT neck carefully. If you break it, flying glass can injure anyone within a radius of six to ten feet.

8. Reconnect the filament harness to the CRT neck.
9. Discharge the anode on the CRT (see "Discharging the Anode").
10. Reconnect the anode lead.
11. Replace the back bezel and both barrier plates.
12. Replace the terminal enclosure and keyboard.

Removing and Replacing the CRT/Yoke Assembly

Tools required:

- o No. 2 Phillips screwdriver
- o Flat-bladed screwdriver
- o Alligator clips

To remove the CRT/yoke assembly (see Figure 2-8), follow these steps:

1. Remove the terminal enclosure, keyboard cable, back bezel, and barrier plates.
2. Remove the terminal PCB and insulation sheet.

3. Unscrew the four No. 2 Phillips screws securing the wire frame to the front bezel.

Warning--Handle the CRT carefully. If you break it, flying glass can injure anyone within a radius of six to ten feet.

4. Lift up the wire frame, and remove the CRT/yoke assembly.

Figure 2-8 Removing the CRT/Yoke Assembly

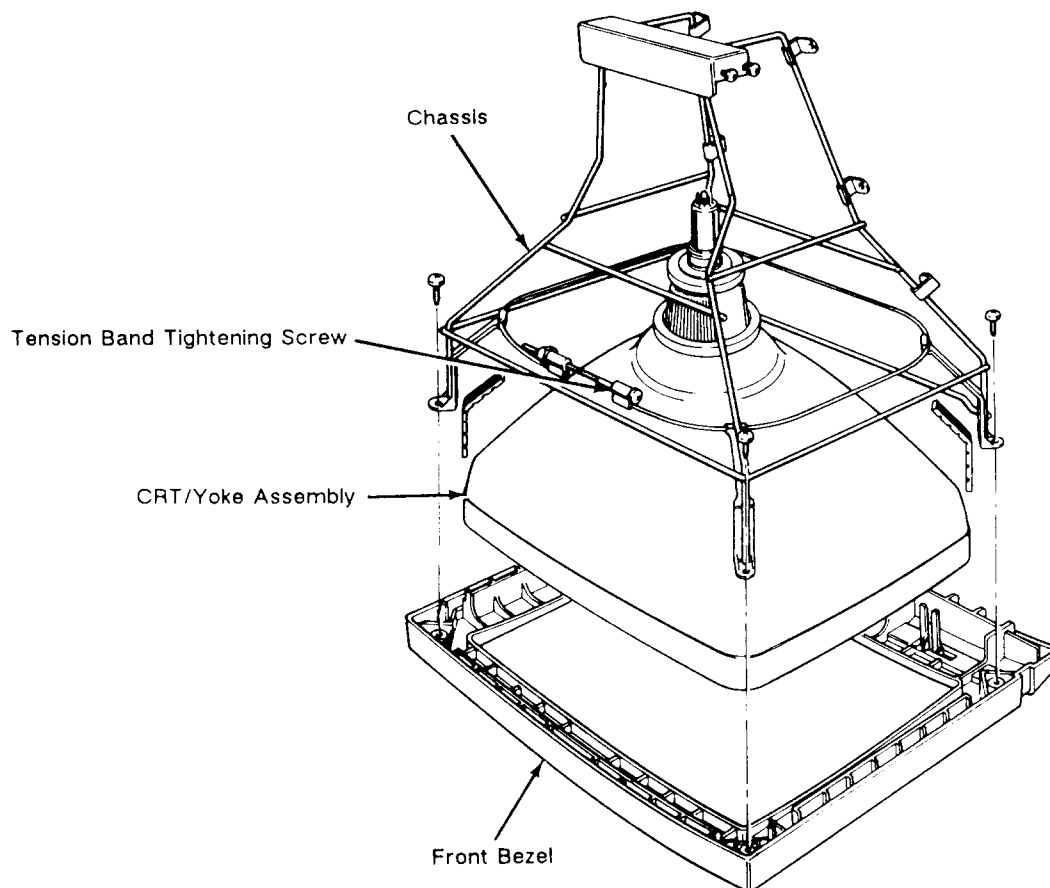

To replace the CRT/yoke assembly, follow these steps:

1. Discharge the anode on the new CRT.

Warning--If you are replacing the same CRT/yoke assembly, you still need to discharge the anode. A CRT left standing for any length of time can develop a charge from the air, and will need to be discharged again.

2. Place the assembly in the front bezel. Make sure the anode faces the keyboard connector jack on the terminal PCB.
3. Fit the wire frame back into the bezel.

4. If necessary, loosen the tension band tightening screw.
5. Replace the four No. 2 Phillips screws that secure the assembly to the wire frame. Tighten.
6. Replace the terminal PCB and insulator sheet.
7. Make sure the tension band is tight. If it isn't, tighten it.
8. Replace the back bezel, barrier plates, and keyboard cable.
9. Replace the terminal enclosure.

Removing and Replacing the Yoke

Tools required: None

To remove the yoke, follow these steps:

1. Remove the CRT/yoke assembly from the terminal.
2. Loosen the yoke lock on the neck of the CRT (see Figure 2-9).
3. Remove the yoke.

Figure 2-9 Replacing the Yoke

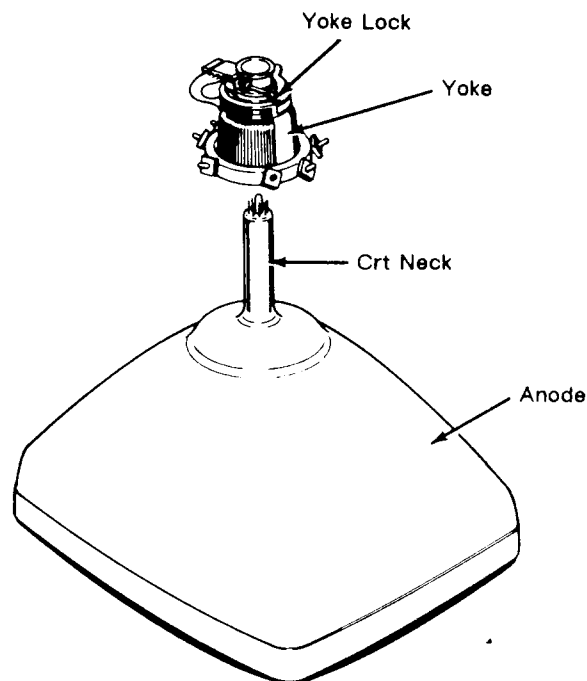

To replace the yoke, follow these steps:

Warning--Before you reattach the yoke assembly, you must discharge the anode. A CRT left standing for any length of time will develop a charge from the air, and need to be discharged again.

1. Position the yoke on the neck of the CRT (see Figure 2-9).
2. Tighten the yoke lock.
3. Replace the CRT/yoke assembly in the terminal.

Replacing the Terminal Enclosure

Tool required:

- o No. 2 Phillips screwdriver

To replace the terminal enclosure, follow these steps:

1. With the terminal face on a nonscratch surface, reseal the enclosure over the wire frame into the back bezel.
2. Replace the two No. 2 Phillips screws on the rear of the terminal enclosure. Tighten.
3. Replace the two No. 2 Phillips screws on the bottom of the terminal. Tighten.

Discharging the Anode

Tools required:

- o Insulated flat-blade screwdriver
- o Alligator clips

We have written specific warnings throughout this chapter about discharging the anode on the side of the CRT. If you have never discharged the anode, or need a review, follow these instructions.

To discharge the CRT anode before removal (see Figure 2-10), follow these steps:

1. Turn off the terminal and unplug it from its power source.
2. Remove the terminal enclosure.
3. Ground the shaft of an insulated flat-bladed screwdriver to the terminal wire frame with alligator clips.

Figure 2-10 Discharging the Anode Before Removal

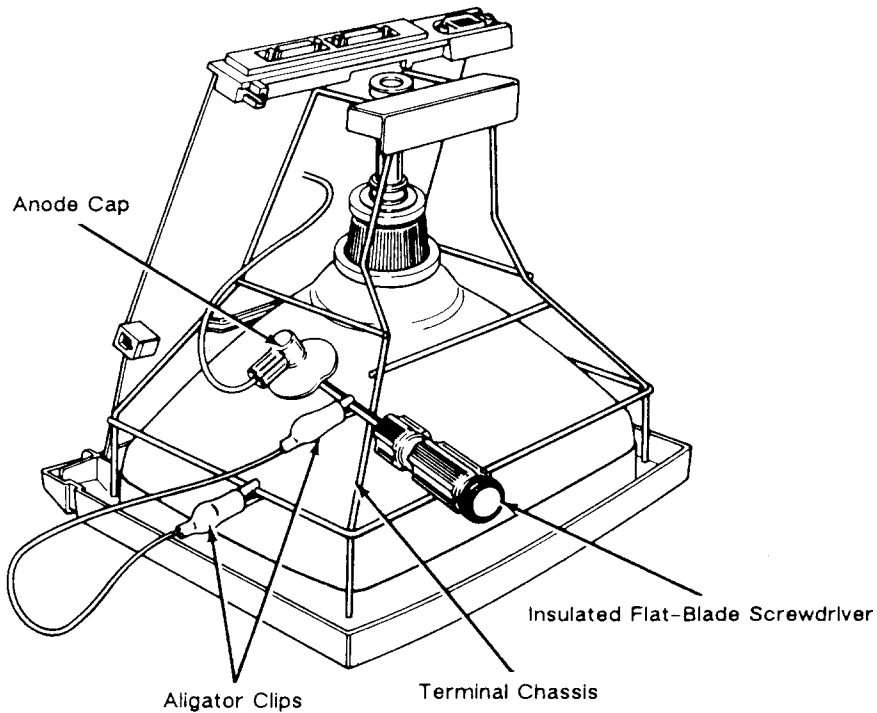

4. Slip the blade between the anode cap and the anode. Touch the blade to the wire anode leads under the cap. Listen for a popping or crackling sound.
5. Remove the anode lead.

To discharge the anode before installation (See Figure 2-11), follow these steps:

1. Ground the shaft of an insulated flate-bladed screwdriver.
2. Touch the blade of the screwdriver to the anode. Listen for a popping or crackling sound.
3. Install the CRT.

Figure 2-11 Discharging the Anode Before Installation

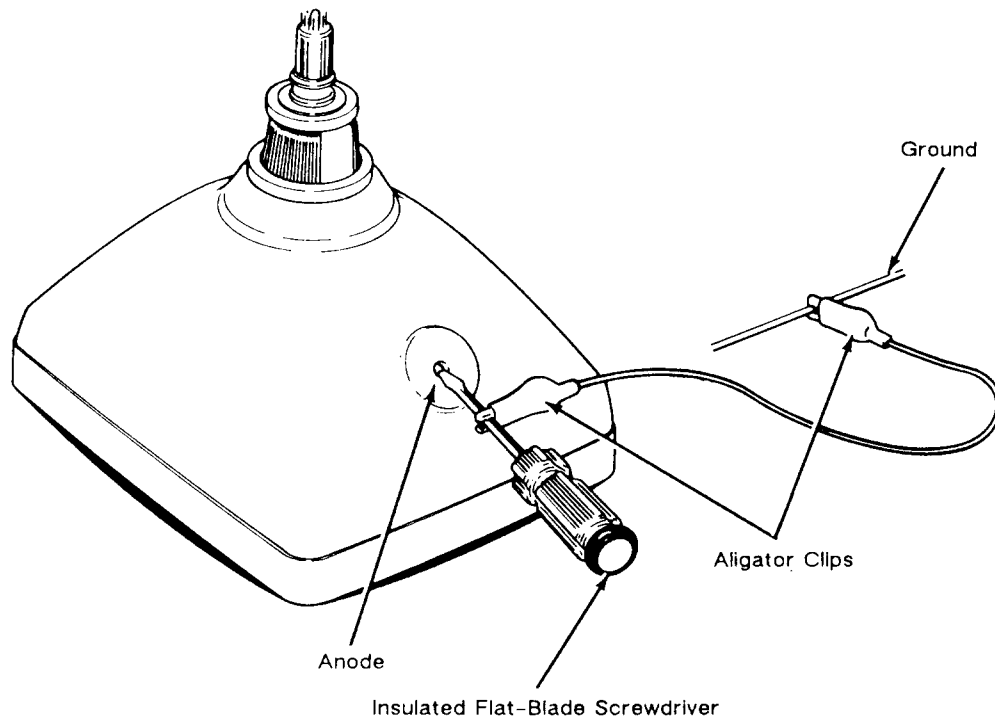

3 TROUBLESHOOTING

Before You Start	3-1
Safety	3-1
Required Tools	3-2
Primary Troubleshooting Procedures	3-2
Preparing the Terminal for Troubleshooting	3-2
Power-On Self Test	3-3
Diagnostic Self-Test	3-3
Back-to-Back Diagnostic Self-Test	3-4
Troubleshooting Quick Reference Guide	3-4
Troubleshooting Flowchart	3-5
No Video/No Beep	3-7
Dim Video	3-10
Other Video Problems	3-10
Fails Self-Test of Diagnostic Tests	3-10
Miscellaneous Symptoms	3-12
Additional Troubleshooting Procedures	3-12
Installation Checklist	3-13
Checking for Continuity	3-14
Power Supply Check on the Terminal PCB	3-14
Checking the Keyboard	3-15
Isolating Circuits	3-15

BEFORE YOU START

Read the following safety information carefully before you attempt to troubleshoot your unit.

Safety

Warning--This terminal contains high voltage. Don't attempt to service the terminal without taking all the precautions necessary for working with high voltage, including the following:

- o If you must open the terminal for any reason, turn off the power, disconnect any communication cables, and unplug the terminal.
- o Remove any jewelry, especially from your hands and wrists.
- o Avoid wearing clothing that holds a static charge.

- o Use only insulated or nonconductive tools.
- o Whenever you disconnect the anode from the anode lead, make sure to discharge the anode as directed in Chapter 2.
- o If you need to remove or replace the CRT/yoke assembly, remember that the CRT can implode if you drop it or break the neck. The flying glass can injure anyone within a radius of six to ten feet.

Required Tools

Before you start to repair in the terminal, make sure you have the tools and materials listed below.

- o No. 2 Phillips screwdriver
- o 3/16-inch flat-bladed screwdriver
- o Digital multimeter (DMM) or a voltmeter
- o Test connectors for the MODEM and AUX ports (See Appendix C for instructions to make them or Chapter 5 for ordering information.)
- o Nonconductive video alignment tool
- o Tie-wraps and diagonal cutters to cut tie-wraps

PRIMARY TROUBLESHOOTING PROCEDURES

You should begin troubleshooting by preparing the terminal properly and running the Power-On Self-Test and the Diagnostic Self-Tests. These tests generate error messages, which are identified in the "Fails Power-on or Diagnostic Self Tests" section of Figure 3-1.

Preparing the Terminal for Troubleshooting

To prepare the terminal for troubleshooting, follow these steps:

1. Turn off the terminal.
2. Disconnect the computer's communication cables.
3. Unplug the power cord from its power source.
4. Remove the terminal bucket and back bezel.
5. Plug the power cord back into it's power source.
6. Turn on the terminal.

Power-on Self-Test

The power-on self-test checks the terminal's random access memory (RAM), read-only memory (ROM), electrically erasable read-only memory (EEROM), and external communication ports.

Each time you turn the terminal on, the power-on self-test occurs. If the test detects an error, an error message appears on the display. The "Fails Power-on or Diagnostic Self-Tests" section in Figure 3-1 identifies these errors. If any of these messages appear, replace or troubleshoot the terminal PCB.

Diagnostic Self-Test

The terminal diagnostic self-test starts in setup mode. This procedure includes communications circuitry tests, read/write tests, and row buffer tests. Two special test connectors allow the diagnostic test to function (see Appendix C for connector definitions or Chapter 5 for ordering information). After you start it, the diagnostic test continues to run until you stop it. If the test detects an error, an error message appears in the lower right-hand corner of the screen (see "Fails Power-on or Diagnostic Self-Tests" in Figure 3-1).

Follow these steps to start the diagnostic self-test:

1. Turn the terminal off.
2. Detach any communications cables on the back of the terminal.
3. Attach the test connectors to the MODEM and AUX ports on the rear of the terminal.

Note--See Appendix C for a description of these test connectors and instructions to make them. See Chapter 5 to order them.

4. Turn the terminal on.
5. Hold the SHIFT key, then press the SETUP key.
6. Press the F2 key. Look for to the TEST:OFF field in the setup menu.
7. Use the cursor keys to highlight the TEST:OFF field.
8. Press the SPACEBAR. This toggles the TEST field ON.
9. Press the F10 key, then CUSOR RIGHT, then F10 again. You will see a flashing test pattern.
10. If the test stops, the terminal beeps, and a letter or number appears on the screen go to the "Fails Power-on or Diagnostic Self-Tests" section of Figure 3-1.

Note--To fully test the terminal, let the diagnostic self-test run five minutes.

11. If you see an error message, replace or troubleshoot the terminal PCB; if you don't see an error, press the SPACEBAR, then the SETUP key.
12. Turn the terminal off. Remove the test connectors, and reattach the communications cables.

Back-to-Back Diagnostic Self-Test

The back-to-back diagnostic self-test also starts in setup mode. This test checks communications circuitry. A special test harness allows the test to function (see Appendix C for harness definition or Chapter 5 for ordering information). After you start it, the back-to-back diagnostic test continues to run until you stop it. If the test detects an error, an error message appears in the lower right-hand corner of the screen (see "Fails Power-on or Diagnostic Self-Tests" in Figure 3-1).

To start the back-to-back diagnostic self-test, follow the same steps as for the diagnostic self-test (previous page), with the exception of step 3:

3. Attach the test harness to the MODEM and AUX ports on the rear of the terminal.

Note--See Appendix C for a description of the test harness and instructions to make it. See Chapter 5 to order it.

TROUBLESHOOTING QUICK REFERENCE GUIDE

Table 3-1 is a troubleshooting reference guide. Once you discover the major symptoms, this table can quickly direct you to the most likely problem area. However, don't automatically replace the suggested modules until you've studied the problem or checked related details in the troubleshooting flowchart.

Table 3-1 Module-Level Troubleshooting Quick Reference Guide

Symptom	Possible Problem Area(s)
No display	Terminal PCB, CRT/yoke assembly
Poor display quality	Adjustments, terminal PCB
Wrong size display Crooked Too bright Not in focus	Adjustments, terminal PCB, yoke
Fails self-test	Terminal PCB
Fails diagnostic test	Terminal PCB, wrong diagnostic setup, faulty test connectors
Inoperative keys	Keyboard, terminal PCB, keyboard cable
Can't communicate with computer	Setup parameters, terminal PCB, communication cable
Letters or error codes on the screen	Terminal PCB

TROUBLESHOOTING FLOWCHART

Read the troubleshooting flowchart and match the symptoms with the suggested solutions. Use the schematics and assembly drawings in Chapter 7 to help you interpret this flowchart.

Figure 3-1 Troubleshooting Flowchart, page 1 of 7

Start

Prepare terminal for troubleshooting	3-2
Symptom: No beep	3-7
Symptom: No video	3-7, 3-10
Symptom: Dim video	3-10
Symptom: Single line of video on screen	3-10
Symptom: Vertical roll	3-10
Symptom: Raster, no video	3-10
Symptom: Letter on screen before diagnostic self-test	3-10
Run diagnostic self-test	3-3
Symptom: Letter on screen after diagnostic self-test	3-10
Symptom: Poor display quality	Chapter 4, Perform full alignment
Symptom: Keyboard not operating	3-12
Symptom: Communication problems	3-12
Symptom: Characters scrambled or degraded, dots missing	3-12
Symptom: Characters don't appear on the screen	3-12

End

Figure 3-1 Troubleshooting Flowchart, page 2 of 7

No Video/No Beep

1. Check power cord, on/off switch, fuse
Check for continuity and correct connections.
Make sure J102 is set for the correct line voltage.
2. Check beeper B1 and surrounding circuitry
3. Check brightness
Check the brightness slideswitch; perform the brightness alignment. (See "Brightness" in Chapter 4.)
4. Check all power supplies
+5V, U1-40, (U1-20 is ground)
+12V, U27-14 (U27-7 is ground)
-12V, U27-1 (U27-7 is ground)
If one of the power supply voltages is out of tolerance, use the schematics found in Chapter 7 to trace and fix the problem.
5. Check tube filament
Is it glowing? If not, check the tube socket:

Is the socket plugged in?
Are any of the CRT's pins bent?
Check the continuity between the socket and its board connections.
6. Check video transistors
Q402, Q401, Q403, Q404. If any aren't operating correctly, replace.
7. Check U20
Look for video output:
Video 0, U20-14
Video 1, U20-15

Check both lines with an oscilloscope, you should see toggling activity on both. If you don't, check these areas:

Dot Clock at U20-1. Look for a 50 percent duty cycle at 26.58 or 39.71 MHz.

If the waveform is missing or incorrect, remove U20 and troubleshoot the dot clock. Check U21 and the surrounding circuitry. Then check U20-1 again.

Figure 3-1 Troubleshooting Flowchart, page 3 of 7

No Video/No Beep, Continued

7. Check U20
(continued)
- If the waveform is correct, check the character clock output at U20-8. Look for 2.658 or 4.4122 MHz. If the output is missing, replace U20.
- Check for shorts on the video output lines: U20-14, U20-15, Q403, Q404, R25, and R26. Are these lines open?
- Check the video blank line, U20-9.
- Check HSYNC: Is U20-7 toggling? Look for 26.58 KHz. Is the line open or short? Check R201.
- Is HSYNC present from the video controller at U20-10? If the signal is present, replace U20. If the signal isn't present, check U19-9.
- Check MBC2 at U20-11, U23-11, and U20-4. Is the signal toggling? Is the MBC signal present at U20-4. If the signal is present, replace U20. If the signal isn't present, continue to step 8.
8. Check U9
- Is U9 receiving power? Look for +5V at U9-40. U9-20 is ground.
- Check character clock input. Use the schematics in Chapter 7 to check the circuitry between U20-8 and U9-16. Are there shorts? Is any portion of the circuitry open?
- If the signal is missing and you find no open circuit, replace U20.
- If the signal is missing and you find no shorts, replace U9.
- Check controller select activity at U9-2. If no shorts and no open lines, go to step 9.
- Check interrupt lines:
U9-5 (toggles at 1.5 KHz)
U9-35 (toggles every 16.6ms)
Are they short or open?

Figure 3-1 Troubleshooting Flowchart, page 4 of 7

No Video/No Beep, Continued

8. Check U9
(continued)

If U9 is being addressed by U1, but U9 is not toggling, replace it.

If interrupts are active, but not toggling, go to step 9.

If interrupts are active and toggling, check the soft font data path, U19- C0 to C7.

Check MBC output: If there is no output, check U1, all read/write and data connections.

If no output and selection functions occur, replace U9.

Check HSYNC output U9-19. Look for 26.58 KHz.

9. Check U1

Check power to U1. U1-40, U1-20 is ground.

Check the processor clock: U1-18, U1-19, and connected circuitry including X4, C10, and C11.

Check signal PSEN, U1-29 to U6-22. If there is no activity present, check U6, U7, U4, U1, their interconnections and all address and data busses connected to U1.

Check signal ALE, U1-30. Look for a signal at 1/12th the clock rate. If this signal is not present, check the reset line U1-9, and the processor clock, U1-18 and U1-19.

Check U1-1. In standard operation in 80-column mode, this pin is low. If PSEN and ALE are functioning and this line is high, check all address and data busses.

Is U6 plugged into its socket backwards?

Figure 3-1 Troubleshooting Flowchart, page 5 of 7

Dim Video

1. Check user brightness control Adjust the brightness slideswitch.
2. Adjust brightness Perform the brightness alignment found in "Brightness", Chapter 4.
3. Check brightness circuitry Check VR202, VR203, VR204, D203, and D205.

Pin 1 of the CRT (attached to the green wire) should vary between +12 and -100VDC when the brightness control slideswitch moves from its highest to its lowest points. Check all connected circuitry.

Check video output pins on U20.

Other Video Problems

1. A vertical line of video Check the vertical yoke and the vertical deflection circuit.
2. A horizontal line of video Check the yoke.
3. Raster, no video Check the video amplifier, U20, all open video lines, and the CRT socket.

Fails Self-Test or Diagnostic Test

1. Check setup Make sure you correctly selected the diagnostic test.
2. Check loopback connectors They may be missing, on the wrong ports or faulty. Check Appendix C to make sure all connections are correct.

If a letter has appeared on the screen, before running the self-test, or you have run self-test, and one or more letters or numbers appear on the screen, check the error codes below and their corresponding recommended actions. All components referred to are found on the logic PCB unless otherwise stated.

Figure 3-1 Troubleshooting Flowchart, page 6 of 7

Fails Self-Test or Diagnostic Test, Continued

Error Code	Indication	Recommended Actions
0	Problems accessing character RAM U7	a. Check U1, U5. b. Check U7.
1	Problems accessing attribute RAM U8	a. Check U1, U5. b. Check U8.
9	Problems accessing U2	a. Check U1-2, -3. b. Check power at U2-8. Look for +5V. U2-4 is ground. c. Check clock and data signals at U2-5 and U2-6. d. Replace U2.
A, C	MODEM port loop-back error	a. Check signals DTR and DCD for signal levels at U3 (UART). b. Check receivers and transmitters U25 and U26. c. Check X3.
E	AUX port loop-back error, DSR-DTR	a. Check U1-4, U1-5. b. Check U27 and U28.
K	Nonvolatile RAM error	a. Turn the unit off. b. While pressing the SETUP key, turn the power on. Continue to press the SETUP key until the screen flashes.
P	External EPROM error	Replace U6 with appropriate part.
p	Internal ROM error	Replace U1.
W	Send error, MODEM to AUX	Check U28, U26, X31, and U3.
X	MODEM port data error	Check U25, U26, U3.
Y	AUX port data error	Check U28, U27.
Z	Send error, AUX to MODEM	Check U25, U27, X3, and U3.

Figure 3-1 Troubleshooting Flowchart, page 7 of 7

Miscellaneous Symptoms

Keyboard not operating	<ol style="list-style-type: none">a. Check keyboard cable for continuity.b. Perform the keyboard test (see "Checking the Keyboard" in this chapter).c. Check connector J1 on the keyboard PCB for shorts or breaks, repair if necessary.d. Check U1 (keyboard scanner) on the keyboard PCB for correct operation. Replace if necessary.e. Check U23 on the terminal PCB.
Communication problems	<ol style="list-style-type: none">a. Check setup information against the host's requirements. Change to match.b. See information related to communication error codes on page 3-11.
Characters scrambled or degraded, dots missing	Check U16, U19, U20.
Characters don't appear on the screen	Check U19 and U20. If the cursor and the status line appear, assume a communications problem. See the information related to communications error codes on page 3-11.

ADDITIONAL TROUBLESHOOTING PROCEDURES

This section contains a number of specialized procedures to help you repair the terminal. Some of them are referenced on the troubleshooting flowchart.

Installation Checklist

The checklist in Table 3-2 helps you to quickly determine if the terminal is installed correctly. If a user installs the terminal incorrectly, it may not function properly.

Table 3-2 Terminal Installation Checklist

o **Environment**

___ Room temperature is between +40 and +91 degrees Fahrenheit (5 and 33 degrees Celsius).

___ Terminal isn't near a magnetic field.

o **Keyboard**

___ Keyboard cable is in the keyboard connector jack on the left side of the terminal.

___ Keyboard cable is in the connector jack on the rear of the keyboard.

o **AC Power Cord**

___ Female end of the power cord is plugged into the AC power socket on the rear panel of the terminal.

___ Male end of the power cord is plugged into wall socket.

o **Communication Interface Cable**

___ One end of the RS-232C interface cable is connected to the MODEM port on the terminal's rear panel.

___ The other end of the interface cable is correctly connected to the computer.

o **Computer Interface** (You'll need to check the computer's documentation to determine the following information.)

___ Correct baud rate

___ Correct stop bits

___ Correct data bits

___ Correct parity type

___ Correct handshaking protocol

Checking for Continuity

Sometimes you can fix the problem without opening the terminal. The problem could be a damaged cable or power cord. Sometimes, you may need to open the terminal to check the fuse or internal connections. Check this list, then, with an ohmmeter, check the continuity of the components listed below.

Outside the terminal, check the

- o Power cord
- o Communication cable (supplied with the computer)

Inside the terminal, check the

- o Fuse
- o AC power input receptacle (on the rear panel of the terminal)
- o Terminal PCB to the CRT/yoke wiring harness

Hold the probes in place for five seconds, or until the ohmmeter settles, to ensure an accurate reading. If the part in question is open, replace it.

Power Supply Check on the Terminal PCB

You can quickly isolate problems if you check power supply voltages on the terminal PCB.

Tools required:

- o No. 2 Phillips screwdriver
- o Digital multimeter
- o Nonconductive video alignment tool

To check the voltages, follow these steps:

1. Turn the terminal off.
2. Remove the terminal enclosure.
3. Attach one lead from the DMM to the chassis as ground.
4. Turn the terminal on.

5. With the other lead from the DMM, look for the following voltages at the specified points on the terminal PCB:

Voltage	Point
+5V <u>±</u> 5%	U1-40 (U1-20 is ground)
+12V <u>±</u> 5%	U27-14 (U27-7 is ground)
-12V <u>±</u> 5%	U27-1 (U27-7 is ground)

6. If one or more of these voltages are not in tolerance, adjust VR101.
7. If you adjust VR101, and the voltage or voltages are still not within tolerance, replace or troubleshoot the terminal PCB.

Checking the Keyboard

If you suspect the keyboard is the source of the problem, follow this procedure to verify it:

1. Turn the terminal off.
2. Disconnect the communication cable.
3. Connect pins 2 and 3 on the MODEM port.
4. Turn the terminal on.
5. The terminal should be in FDX (full-duplex) mode. (If it isn't, go into setup mode, select the FDX parameter, then leave setup mode.)
6. Type on the keys. Test all the keys in shifted and unshifted positions. If the keys don't respond, see section E of "Troubleshooting Flowchart."

Isolating Circuits

If you troubleshoot to the component level using the schematics in Chapter 7, you may want to isolate the logic, monitor, or power supply circuitry. Table 3-6 is a list of jumpers on the terminal PCB and the areas they isolate. For an exact location, see the terminal PCB component layout in Chapter 5.

Table 3-3 Terminal PCB Circuit Isolation Jumpers

Jumper	Areas Isolated
J681	Power supply from logic
J682	+5 volt supply
J759	Video circuit
J760	Logic from monitor circuitry
J532	Video 0
J533	Video 1
J665	Vertical synchronization
J535	Logic from monitor circuitry
J583	Horizontal synchronization
J749	Logic from monitor circuitry

For Service Manuals
MAURITRON SERVICES
8 Cherry Tree Road, Chinnor
Oxfordshire, OX9 4QY.
Tel (01844) 351694
Fax (01844) 352554
email:- mauritron@dial.pipex.com

4 ADJUSTMENTS AND ALIGNMENTS

Before you Start	4-1
Safety Summary	4-2
Required Tools	4-2
Checking Display Specifications	4-2
Aligning the Terminal Display	4-5
Adjusting the Terminal Display	4-10
Vertical Hold	4-10
Height	4-11
Width	4-11
Yoke Lock	4-11
Centering Rings	4-11
Display Magnets	4-13
Brightness	4-14
Focus	4-14
Linearity	4-15
Test Patterns	4-15
Pattern M	4-15
Pattern O	4-16

BEFORE YOU START

This chapter describes adjustments and alignments for the terminal. In particular, it discusses voltage adjustments, full monitor alignment, and individual adjustments. Before you align the monitor, check to see if the display meets the specification. If it doesn't, follow the set of instructions in the alignment section. You should complete a full terminal alignment whenever you replace the terminal printed circuit board (PCB) or the cathode ray tube (CRT)/yoke assembly.

WARNING--The CRT/yoke assembly has high voltages. Only qualified service personnel should adjust it.

Safety Summary

This terminal contains high voltage. Don't attempt to service the terminal without taking all the precautions you need for working with high voltage.

- o If you must open the terminal for any reason, first turn off the power and unplug the terminal.
- o Remove any jewelry, especially any on your hands, wrists, or neck.
- o Avoid wearing clothing that carries a static charge.
- o Use only insulated or nonconductive tools.
- o If you need to remove or replace the CRT/yoke assembly, remember that it can implode if you drop it or break the neck. The flying glass can injure anyone within a radius of ten feet.

Required Tools

Before testing the power supply voltages or making any adjustments to the terminal display, make sure you have the tools listed below:

- o Flat-bladed nonconductive alignment tool
- o Hex nonconductive alignment tool
- o No. 2 Phillips screwdriver
- o Digital voltmeter (DVM)
- o Millimeter ruler or reticle (the reticle is optional--see Appendix D for instructions on how to use the reticle when you check the display.)
- o Diagnostic test connectors (see Chapter 5 to order them or Appendix C to make them)

CHECKING THE DISPLAY SPECIFICATION

Before you adjust the display on the monitor, measure the screen margins and study the display.

Tools required:

- o Millimeter ruler or reticle (reticle is optional)
- o Diagnostic test connectors

Follow this procedure to determine whether or not the display is within specification. Notice that the procedure contains two columns, one to describe specific actions and one for comments and descriptions.

ACTION

COMMENTS

- | | |
|--|--|
| 1. Turn off the terminal. Unplug it from its AC power source and disconnect any communications cables. | |
| 2. Attach the diagnostic test connectors to the MODEM and AUX ports on the rear panel of the logic pedestal. | See Chapter 5 if you need to order these connectors or Appendix C for instructions to make them. |
| 3. Plug in the terminal and turn it on. Let the terminal run for 30 minutes. | Before you check the display to determine if the power supply or monitor assembly need adjustments or alignment, let the terminal run for 30 minutes. This assures you that the display is stable and will not drift or display other distortion after you measure it. |
| 4. Hold the SHIFT key, then press the SETUP key. | |
| 5. Press the F2 function key. | Look for the TEST=OFF field in the third line of the setup menu. |
| 6. Press the CURSOR DOWN key twice. Press the CURSOR RIGHT key once. | |
| 7. Press the SPACEBAR. | This toggles the TEST field ON. |
| 8. Press the F10 key. | |
| 9. Press CURSOR RIGHT once. | |
| 10. Press the F10 key again. | This saves the selection you've made and start the diagnostic self-test. You should see a flashing test pattern of asterisks. |

ACTION

COMMENTS

11. Wait until the screen displays the Walking RAM Character Test, then hold down the SPACEBAR until the test pattern stops flashing.

You will see the test pattern M.
12. Call test pattern O by pressing the CTRL and A keys simultaneously.

You can toggle between patterns O and M with the CTRL A keystroke command. Both test patterns are described and illustrated in "Test Patterns" in this chapter.

When toggling between test patterns O and M, you will find another pattern--the character/attribute test pattern. It contains several rows of characters, each displayed with a different attribute. Look at this pattern when you are troubleshooting. You should not depend on measurements from this test pattern during alignment.
13. If you don't have a reticle, measure the margins on the top, bottom, and both sides of test pattern O with a millimeter ruler.

Each margin should measure 11mm +2mm. If they don't, see "Aligning the Terminal Display."

If you have a reticle, see Appendix D.
14. Look at the display.

If there is barreling or pincushioning, if any of the display edges aren't straight, or if there are size or centering problems, see "Aligning the Terminal Display."
15. Press CTRL A.

You will see test pattern M on the screen.

ACTION

COMMENTS

16. Look at the display.
- Check for brightness balance between the three blocks, making sure that the raster doesn't show when operator brightness slideswitch is pushed completely to the right.
17. Look at the display again.
- Are the letters on the top of this pattern the same size as the letters at the bottom? Are they the same size throughout? Are there any focus problems on the screen? If there are problems, skip steps 15 and 16. Go to "Aligning the Terminal Display."
18. If the display is within specification and looks regular, press the SETUP key.
19. Turn the terminal off. Remove the connectors and reattach the communications cables.

ALIGNING THE TERMINAL DISPLAY

The monitor has several alignments and adjustments. If the terminal display is out of tolerance in one or two areas, make adjustments to correct those problems with individual adjustments suggested in Table 4-1. If you change the CRT, the yoke, the CRT/yoke assembly, or the terminal PCB, you must perform a full alignment. **Follow these procedures only if the display is out of tolerance and doesn't match the specification.**

Required tools:

- o Flat-bladed nonconductive alignment tool
- o Hex nonconductive alignment tool
- o No. 2 Phillips screwdriver
- o Digital voltmeter (DVM)
- o Diagnostic test connectors

WARNING--The CRT/yoke assembly has high voltages. Only qualified service personnel should perform these adjustments.

Follow these steps to align the terminal display. Notice that the procedure has an action column that describes each step and a comments column that describes symptoms you should look for or other information that will help you with that step.

Note--If you already have one of the test patterns on the screen, remove the terminal bucket and go to Step 10.

ACTION	COMMENTS
1. Turn off the terminal. Unplug it from its AC power source and disconnect any communications cables.	
2. Remove the terminal bucket.	See Chapter 2.
3. Attach test connectors to the MODEM and AUX ports on the rear panel of the logic pedestal.	See Chapter 5 if you need to order these connectors or Appendix C for instructions to make them.
4. Plug in the terminal and turn it on. Let the terminal run for 30 minutes.	Before you check the display to determine if the power supply or monitor assembly need adjustments or alignment, let the terminal run for 30 minutes. This assures you that the display is stable and will not drift or display other distortion after you measure it.
5. Hold the SHIFT key, then press the SETUP key.	
6. Press the F2 function key.	Look for the TEST=OFF field in the third line of the setup menu.
7. Press the CURSOR DOWN key twice. Press the CURSOR RIGHT key once.	
8. Press the SPACEBAR.	This toggles the TEST field ON.
9. Press the F10 key.	
10. Press the CURSOR RIGHT key once.	

ACTION

COMMENTS

11. Press the F10 key again.

This saves the selection you've made and starts the diagnostic self-test. You should see a flashing test pattern of asterisks.
12. Wait until the screen displays the scrolling ASCII test pattern, then hold down the SPACE BAR until the test pattern stops flashing.

You will see test pattern M.
13. Call test pattern O by pressing the CTRL and A keys simultaneously.

You can toggle between patterns O and M with the CTRL A keystroke command. Both test patterns are described and illustrated in "Test Patterns" in this chapter.

When toggling between test patterns O and M, you will find another pattern--the character/attribute test pattern. It contains several rows of characters, each displayed with a different attribute. Look at this pattern when you are troubleshooting. You should not depend on measurements from this test pattern during alignment.
14. Use the DVM to check the +5V supply at R20 on the terminal PCB. The keyboard socket is ground.

See Figure 4-1, "Power Supply Component Layout."
15. Adjust VR101 until the digital voltmeter reads +5V \pm 2 percent.

If you can't adjust the power supply into tolerance, see "Troubleshooting," Chapter 3.

Figure 4-1 Power Supply Component Layout

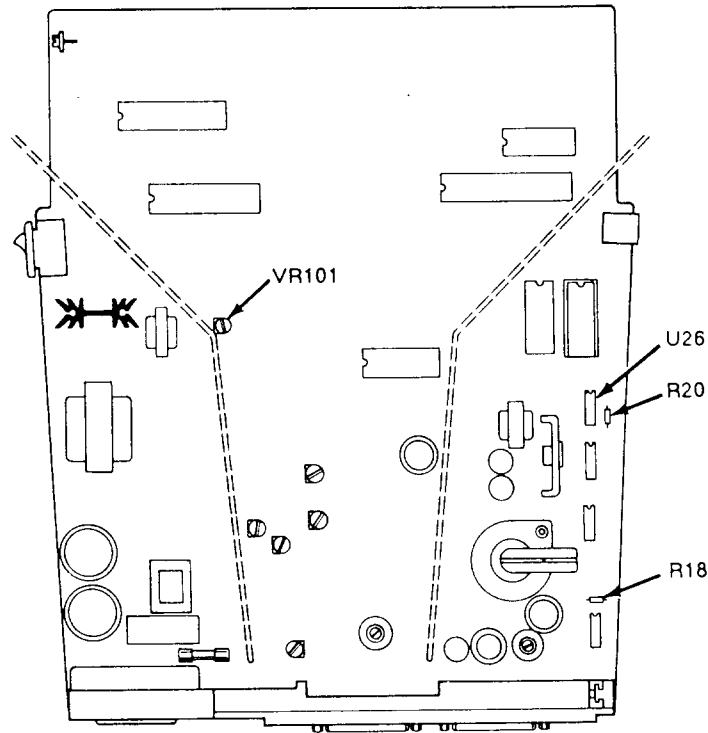

ACTION

16. Check the -12V supply at U26-1.

17. Check the +12V supply at R18.

18. Adjust the display.

COMMENTS

The digital voltmeter should read -12V \pm 5 percent. If the -12V supply is not within tolerance after you have adjusted the +5V supply, see Chapter 3, "Troubleshooting."

The digital voltmeter should read +12V \pm 5 percent. If the +12V supply is not within tolerance after you have adjusted the +5V supply, see Chapter 3.

See Table 4-1 for a list of display problems and their adjustments. Check Figure 4-2 for their related component locations.

ACTION**COMMENTS**

18. (Continued)

Table 4-1 suggests individual adjustments. If a full alignment is needed, make all of the adjustments in Table 4-1, in the order listed.

19. If, after adjustment, the display is within specification and looks regular, press the SETUP key.

Pressing the SETUP key causes the terminal to leave test mode.

If you have adjusted the display and it still doesn't conform to specification, see Chapter 3, Troubleshooting.

20. Turn the terminal off. Close it, remove the connectors, and reattach the communications cables.

Table 4-1 Display Problems and Their Adjustments

Test Pattern	Display Problems	Adjustments	Page
O	Rolling display (early PCBs)	Vertical hold	4-8
O	Too short or too tall	Height	4-8
O	Too wide or too narrow	Width	4-8
O	Tilted	Yoke lock	4-8
O	Not centered	Centering rings	4-8
O	Pincushioning; barreling; crooked edges; corners sag or move out of specification	Display magnets	4-8
M	Too bright; too dim; raster scan lines show; individual problems with full-bright, dim1, or dim2	Brightness	4-11
M	Fuzzy letters	Focus	4-11
M	Letters at the top of the display aren't the same height as those at the bottom of the display	Linearity	4-12

Note--If you finish both the power and display adjustments, and the display is still not within tolerance, see Chapter 3, "Troubleshooting."

ADJUSTING THE TERMINAL DISPLAY

This section contains detailed instructions for each adjustment mentioned in Table 4-1 and a cross reference for the test pattern that you should use when making that particular adjustment. See Figure 4-2 to identify adjustment locations on the terminal PCB. The order in which we have listed adjustments in this section corresponds to the order of full alignments listed in Table 4-1. To perform a full alignment, make all adjustments in the order that follows.

Figure 4-2 Adjustment Locations

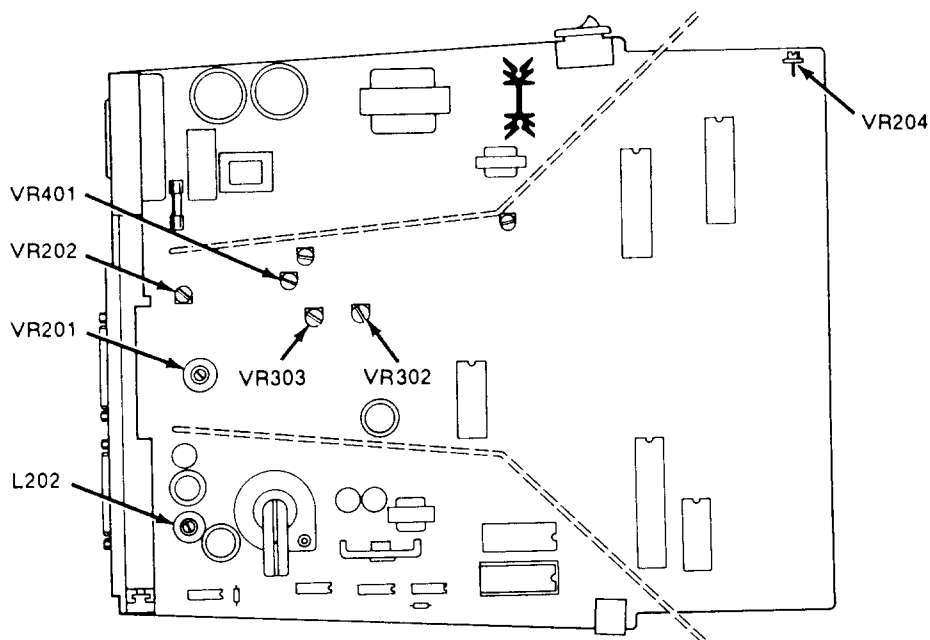

Vertical Hold

On certain early units the vertical hold adjustment is labeled VR301 on the terminal PCB. On most units, VR301 is replaced with a fixed resistor. If you can adjust vertical hold, use display test pattern 0.

Adjust VR301 until the display is steady and doesn't roll.

Height

The height adjustment is labeled VR302 on the terminal PCB. Display test pattern 0.

Adjust VR302 until the top edge and the bottom edge of the display are both 11mm \pm 2mm from the edge of the bezel.

Width

Caution--Do not use a metal tool to adjust the width coil. The magnetic properties of a metal tool will affect the adjustment.

The width adjustment is labeled L202 on the terminal PCB. Display test pattern 0.

Adjust L202 until either side of the display is 11mm \pm 2mm from the edge of the bezel.

Yoke Lock

The yoke lock corrects tilt problems. It is located on the neck of the CRT (See Figure 4-3). Display test pattern 0.

1. Loosen the yoke lock on the neck of the CRT.
2. Rotate the yoke until the top and bottom edges of the display are level with the top and bottom of the bezel.

Warning--Do not tighten the yoke lock too much or the neck of the CRT will break, and shoot broken glass for a radius of six to ten feet.

3. Tighten the yoke lock.

Centering Rings

There are two display centering rings around the yoke. When turned, they move the display position on the screen. Figure 4-4 shows the rings. If the display isn't in the center of the screen, turn the rings until it is.

Figure 4-3 Yoke Lock on the CRT Neck

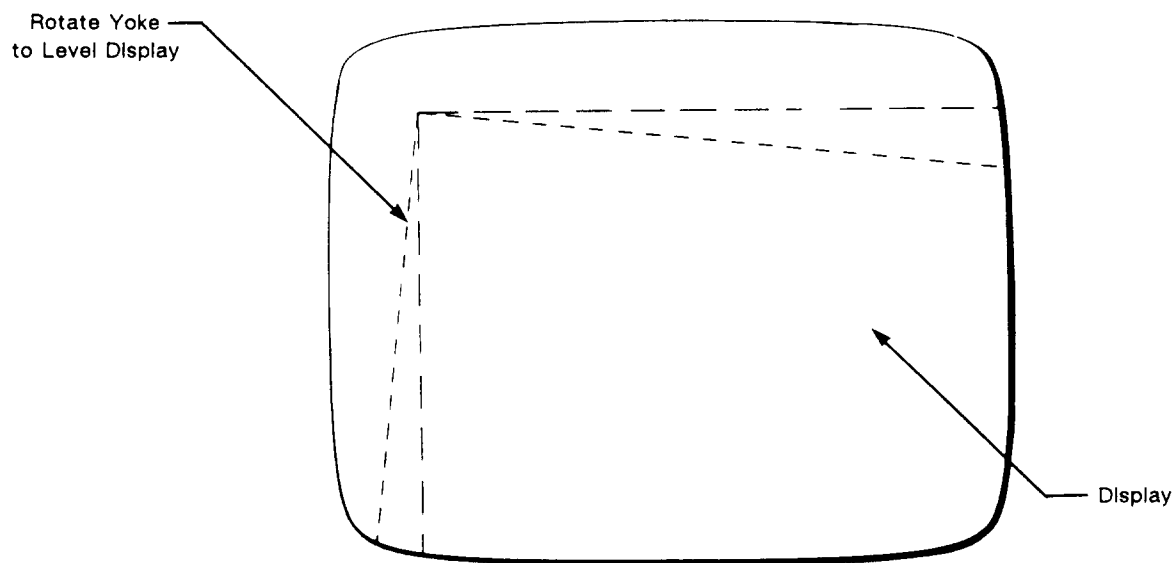
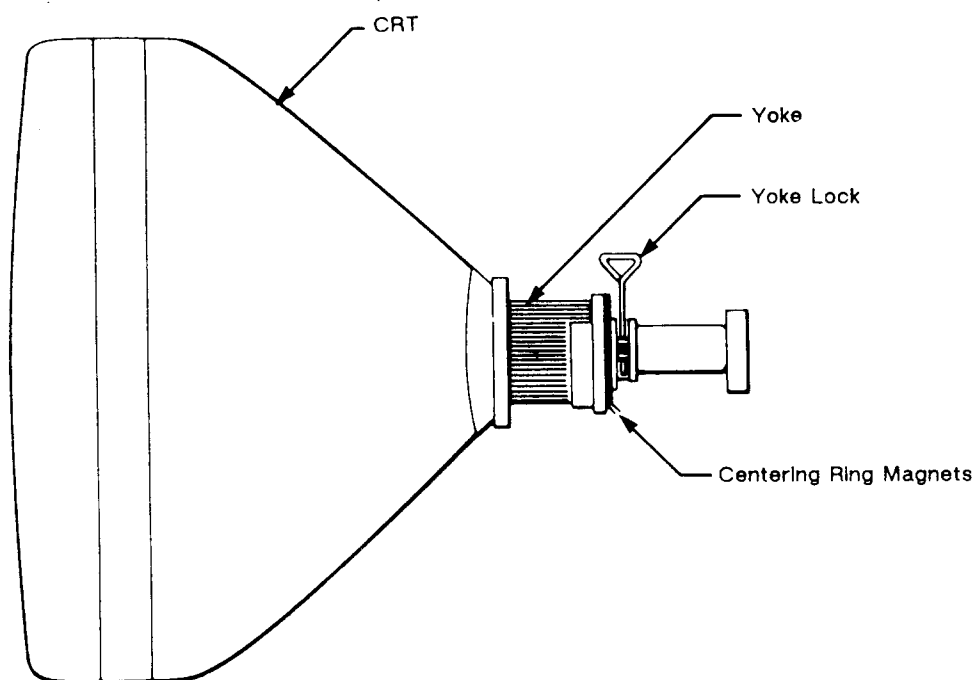
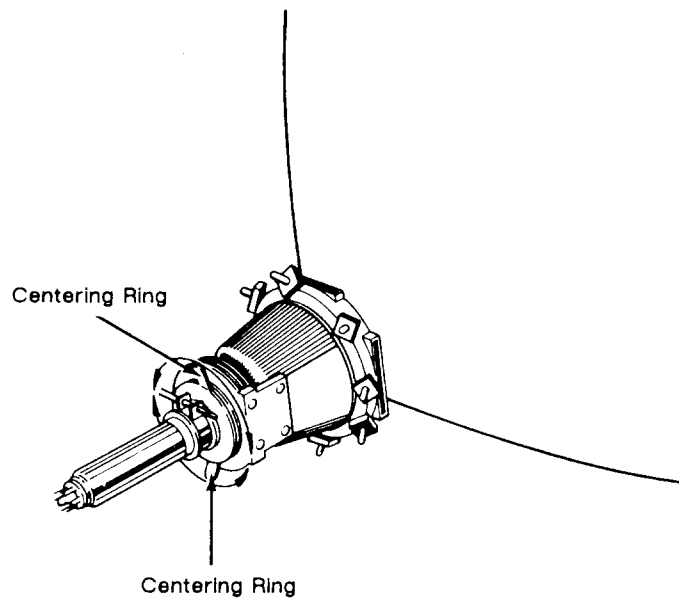

Figure 4-4 Centering Rings



Display Magnets

There are eight display magnets on a ring around the yoke. When turned, they change corresponding screen area. They can also affect adjacent areas. Figure 4-5 identifies each magnet; Table 4-2 identifies which portion of the screen each changes.

Figure 4-5 Display Magnets

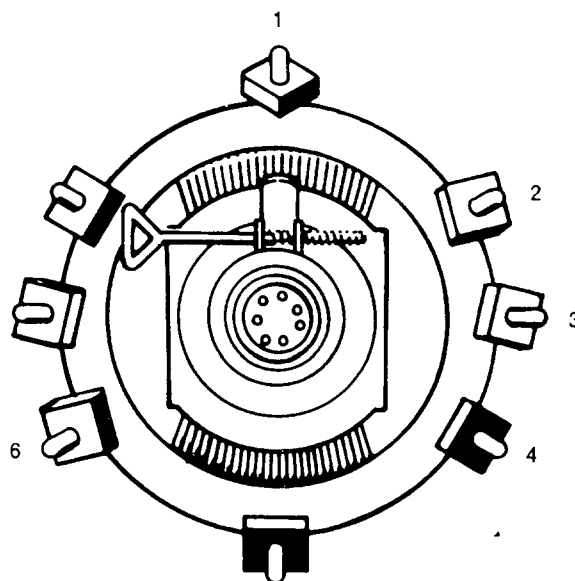

Table 4-2 Screen Areas Affected by Display Magnets

Magnet Number	Area Affected
1	Top
2	Upper left corner
3	Left
4	Lower left corner
5	Bottom
6	Lower right corner
7	Right
8	Upper right corner

Brightness

Note--Excessive brightness can shorten tube phosphor life. You may wish to measure the three brightness levels with a correctly calibrated photometer. See Appendix A for display intensity measurement information.

Three degrees of brightness can be adjusted: normal, dim1, and dim2. Display test pattern M to adjust brightness. Test pattern M has three blocks in the middle of the display showing, from left to right, dim2, dim1, and normal. Follow these steps:

1. Slide the brightness slideswitch as far right as possible.
2. Turn SUB-BRI, VR202 as far clockwise as possible. You will see the raster lines on the screen.
3. Slowly turn VR202 just until the raster is not visible.
4. Look at the outside brightness blocks. If dim2 is too bright or normal is too dark, adjust VR401 until you correct the problem.
5. Slide the brightness slideswitch as far left as possible.
6. Adjust VR204 just until the normal block on the right of the screen is no longer visible.

Focus

Note--Do not use the focus control to adjust the outer extremities of the screen. Some focus distortion happens in any CRT.

The focus adjustment is labeled FOCUS VR201 on the terminal PCB. Display test pattern M. Adjust VR201 until the characters halfway between the center of the display and the bezel are distinct and clear.

Linearity

The linearity adjustment is labeled VR303 on the terminal PCB. Display test pattern M. Adjust VR303 until characters on the bottom of the display are the same height as those on the top.

TEST PATTERNS

Two alignment test patterns are stored in read-only memory (ROM): pattern M and pattern O. (A third pattern, the character attribute pattern, is used for diagnostic purposes only.)

Pattern M

Pattern M helps you detect and correct linearity, brightness, and focus. See Figure 4-6.

Figure 4-6 Pattern M

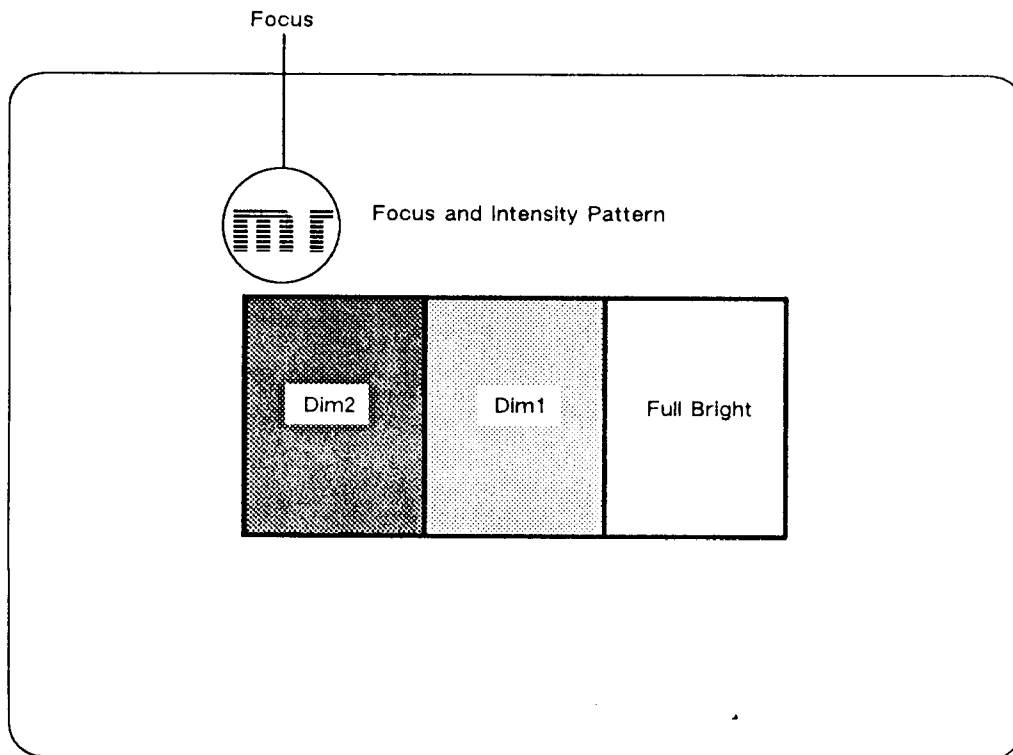

This pattern is an 80 or 132-column display of characters. (Hold the CTRL key and press the S key to toggle between 80 and 132 columns.) Three blocks in the center of the pattern indicate brightness: bright, normal, and dim.

Pattern 0

Pattern 0 helps you detect and correct pincushion, tilt, centering, and size problems. See Figure 4-7.

This pattern is a full-inverse, normal intensity display in the 80-column format. Two pairs of parallel lines cross in the center, making four quadrants. Two additional vertical lines, one on either side of the pattern, indicate brightness intensity levels.

Figure 4-7 Pattern 0

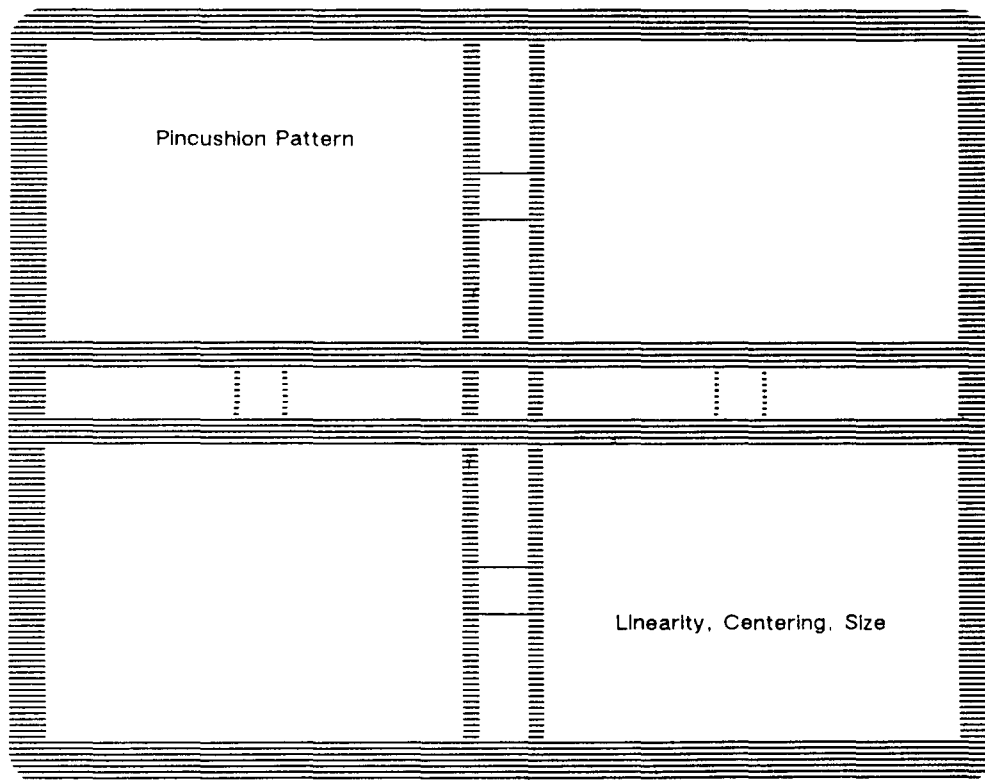

You can verify the display tolerances using both patterns along with a display reticle. See Appendix D for reticle instructions.

5 ILLUSTRATED PARTS LIST

Introduction	5-1
Printed Circuit Board Layout and Component Identification ..	5-2
Terminal Display Assembly Exploded View	5-3
Keyboard Assemblies Exploded Views	5-4
Terminal PCB Components List	5-6
Terminal Board Assembly Layout	5-13
WY-60 ASCII Keyboard PCB Components List	5-14
WY-60 ASCII Keyboard PCB Layout	5-15
316X-Style Keyboard PCB Components List	5-16
316X-Style Keyboard PCB Layout	5-17
AT-Style Keyboard PCB Components List	5-18
AT-Style Keyboard PCB Layout	5-19
Diagnostic Tools	5-20

INTRODUCTION

This chapter provides the information you need to order parts for the terminal.

The first part of this chapter provides four exploded assembly drawings: the terminal display, and the three keyboards. Each replaceable assembly, plastic covering, or cable is labeled on the drawings with a part name and part number.

In the second part of this chapter, we list all piece parts, their values or generic industry numbers when relevant, and their locations on the terminal PCB or the keyboard PCB.

When you order replacement parts, assemblies, or diagnostic tools, please give both the part name and the part number.

PRINTED CIRCUIT BOARD LAYOUT AND COMPONENT IDENTIFICATION

To assist you in identifying components, the text identifies each component with the reference designator found next to the component on all printed circuit boards.

Reference designators are letter and number combinations that identify a given component (see Figure 5-1). The letter designates the kind of component (see Table 5-1).

Figure 5-1 Sample PCB

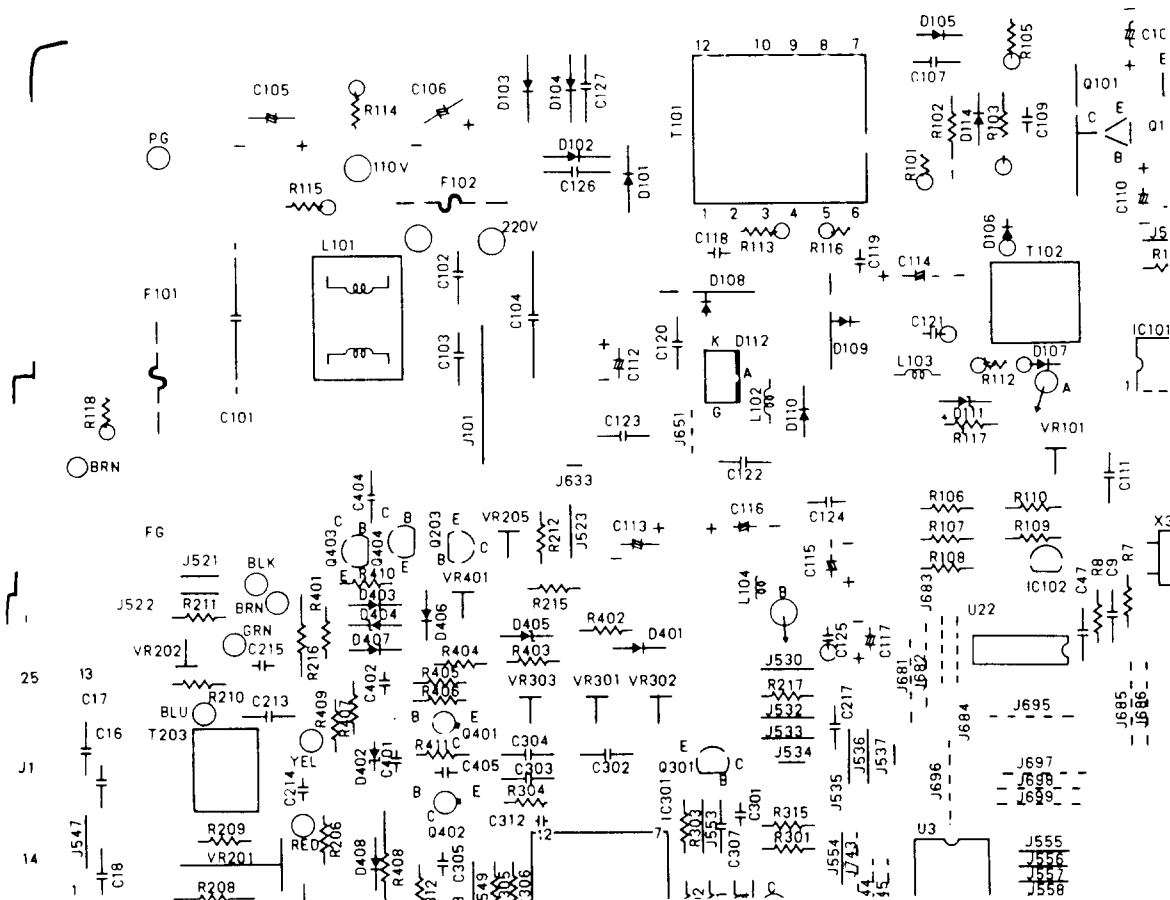

Table 5-1 Reference Designator Letters

Letter	Component
U or IC	Integrated circuit
R	Resistor
C	Capacitor
VR	Variable Resistor or Potentiometer
D	Diode
Q	Transistor

The number next to the letter designates the part on the components list, enabling you to identify the component's Wyse part number, properties, and other generic identifiers.

Figure 5-2 Terminal Display Assembly Exploded View

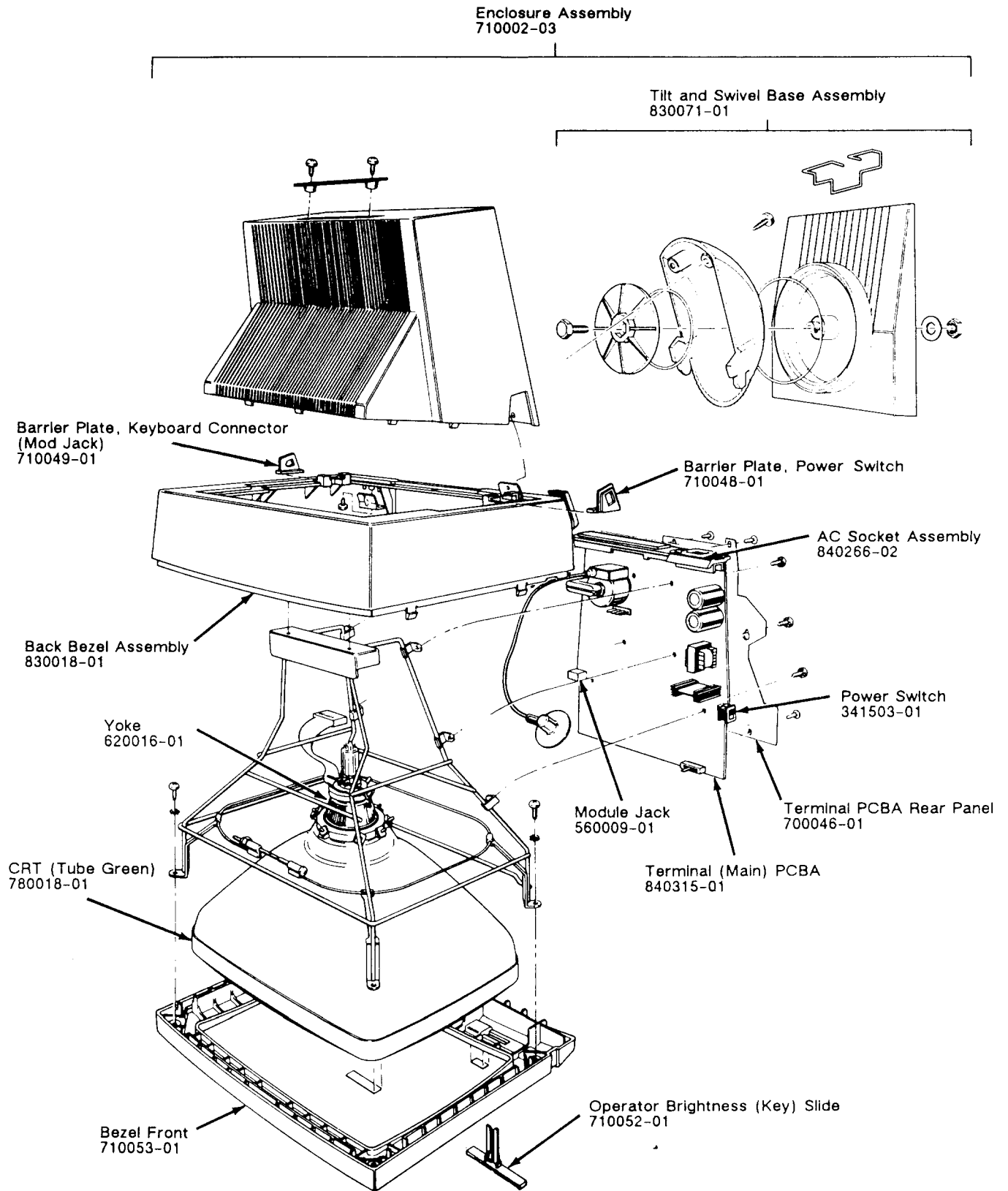
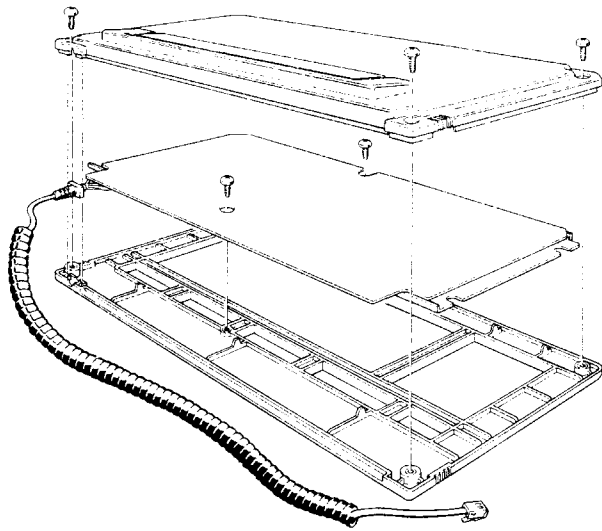
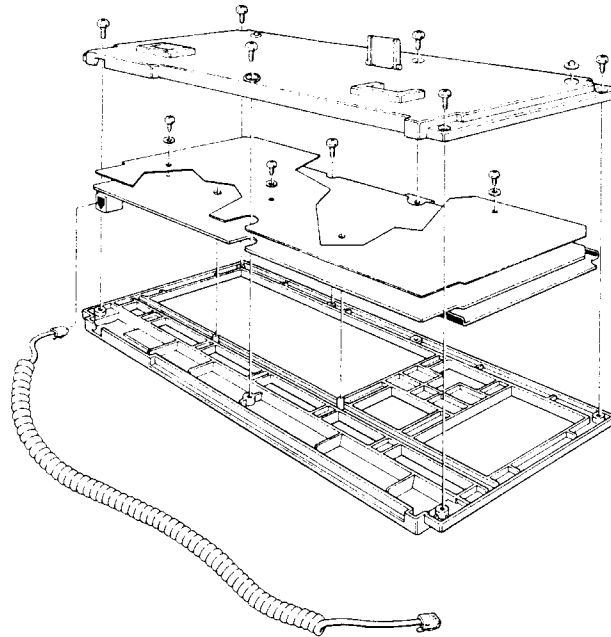

Figure 5-3 Keyboard Assemblies Exploded Views



WY-60 ASCII Keyboard



316X-Style Keyboard

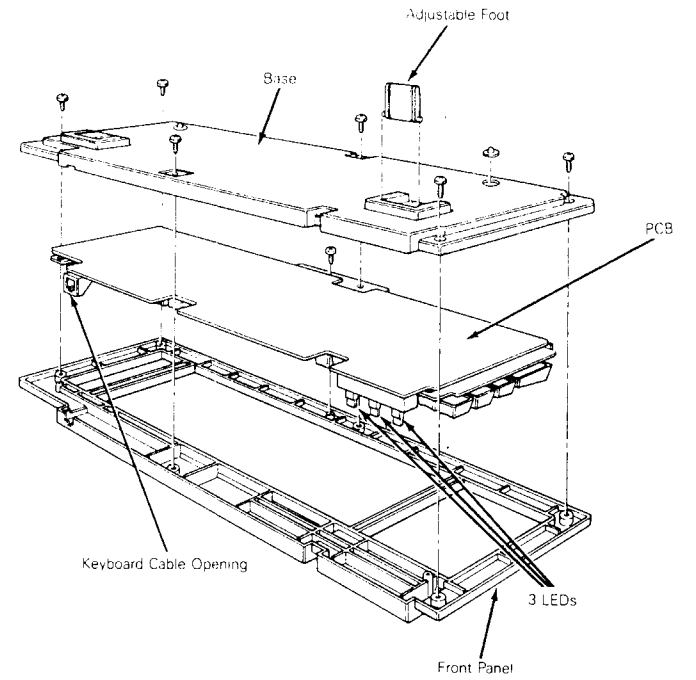

AT-Style keyboard

Table 5-2 Terminal (Main) PCB Components List

Reference Designator	Description	Part
	CRT, CLINTON CE838W14H31GTZ (GREEN)	780018-01
	CRT, CLINTON CE838W14H188GTZ (WHITE)	780031-02
	CRT, CLINTON CE838W14H190GTZ (AMBER)	780031-01
	YOKE, DEFLECTION	620016-01
	TILT SWIVEL BASE ASSY	830071-01
	BEZEL ASSY., BACK	830018-01
	BEZEL, FRONT	710053-01
	PANEL, REAR	700046-01
	COIL CORE HARNESS	940214-01
	AC I/P POWER SW HARNESS	940200-01
	AC I/P HARNESS L=40MM	940202-01
	HARNESS, 1P (JST)	940109-28
	HARNESS, CHASSIS GND.	940153-01
	COIL CORE HARNESS	940214-01
	AC SOCKET ASSY, WY60 INT'L	840266-02
	SOCKET, AC	567502-01
	FUSE, 2A 125VAC 5MT2 (BEL)	530013-19
	FUSE, 1.6A 250VAC 5MT2 (BEL) INT'L	530013-13
	CABLE, POWER CORD	728500-01
J1	CONN., D 25 PIN FEMALE	80-151-77
J2	CONN., D 25 PIN FEMALE	80-151-77
RJ9	MODULE JACK 4P4C	560009-01
	MAIN BD ASSY, WY60 115V	840315-01
	FIRMWARE WY60 27512 EPROM	250245-01
B1	BEEPER, AUDIO TRANSDUCER	522000-01
C2	CAP., MK 120PF 50V J NPO	320012-14
C3	CAP., CNR 270PF 5% 50V	320013-18
C4	CAP., MC, PF, 1200, 50V, J, NPO, AXIAL	320010-38
C6	CAP., MLK 100PF 50V 5%	320006-13
C7	CAP., MK 120PF 50V J NPO	320012-14
C8	CAP., MC, PF, 1200, 50V, J, NPO, AXIAL	320010-38
C9	CAP., MG 470PF 50V (AXIAL)	320010-33
C10	CAP., 33PF 50V	320010-19
C11	CAP., 33PF 50V	320010-19
C12	CAP., AEL 22MF 16V	310003-15
C13	CAP., MG 220PF 50V (AXIAL) (J)	320010-29
C14	CAP., MG 220PF 50V (AXIAL) (J)	320010-29
C15	CAP., MG 220PF 50V (AXIAL) (J)	320010-29
C16	CAP., MG 220PF 50V (AXIAL) (J)	320010-29
C17	CAP., MG 220PF 50V (AXIAL) (J)	320010-29
C18	CAP., MG 220PF 50V (AXIAL) (J)	320010-29
C19	CAP., AEL 100MF 16V	310034-19
C20	CAP., AEL 100MF 16V	310034-19
C21	CAP., MG 220PF 50V (AXIAL) (J)	320010-29
C22	CAP., MG 220PF 50V (AXIAL) (J)	320010-29
C23	CAP., MG 220PF 50V (AXIAL) (J)	320010-29
C24	CAP., MG 220PF 50V (AXIAL) (J)	320010-29

Table 5-2 Terminal PCB Components List, Continued

Reference Designator	Description	Part
C25	CAP., MG 1000PF/50V KX7R	80-960-20
C26	CAP., MG 1000PF/50V KX7R	80-960-20
C27	CAP., MG 1000PF/50V KX7R	80-960-20
C28	CAP., MG .1MF 50V AXIAL	320001-25
C29	CAP., MG .1MF 50V AXIAL	320001-25
C30	CAP., MG .1MF 50V AXIAL	320001-25
C31	CAP., MG .1MF 50V AXIAL	320001-25
C32	CAP., MG .1MF 50V AXIAL	320001-25
C33	CAP., MG .1MF 50V AXIAL	320001-25
C34	CAP., MG .1MF 50V AXIAL	320001-25
C35	CAP., MG .1MF 50V AXIAL	320001-25
C36	CAP., MG .1MF 50V AXIAL	320001-25
C37	CAP., MG .1MF 50V AXIAL	320001-25
C38	CAP., MG .1MF 50V AXIAL	320001-25
C39	CAP., MG .1MF 50V AXIAL	320001-25
C40	CAP., MG .1MF 50V AXIAL	320001-25
C41	CAP., MG .1MF 50V AXIAL	320001-25
C42	CAP., MG .1MF 50V AXIAL	320001-25
C43	CAP., MG .1MF 50V AXIAL	320001-25
C44	CAP., MG .1MF 50V AXIAL	320001-25
C45	CAP., MG .1MF 50V AXIAL	320001-25
C46	CAP., MG .1MF 50V AXIAL	320001-25
C47	CAP., MG .1MF 50V AXIAL	320001-25
C48	CAP., MG .01MF 50V (AXIAL)	320001-13
C49	CAP., MG .01MF 50V (AXIAL)	320001-13
C50	CAP., MICA 47PF	321001-24
C51	CAP., MG .1MF 50V AXIAL	320001-25
C53	CAP., MG .1MF 50V AXIAL	320001-25
C52	CAP., MG .1MF 50V AXIAL	320001-25
C101	CAP., INTERF. SUPP. .47MFD 250VAC	329001-11
C102	CAP., .0047MF 250VAC-Y	329003-06
C103	CAP., .0047MF 250VAC-Y	329003-06
C104	CAP., INTERF. SUPP. .1MFD/250VAC V	329001-07
C105	CAP., AEL 220MF 200V	310088-21
C106	CAP., AEL 220MF 200V	310088-21
C107	CAP., MPF .1MFD 100V	320505-15
C108	CAP., AEL 47MF 25V VT. MNT.	310004-17
C109	CAP., CD 560PF 1KV K Y5P	320039-34
C110	CAP., AEL 10MF 25V VT.MNT	310004-13
C111	CAP., MPF .22MF 100V	80-920-54
C112	CAP., AEL 2200MF 16V	310003-27
C113	CAP., AEL 2200MF 16V	310003-27
C114	CAP., AEL 2200UF 10V 105 DEGREE C	310033-27
C115	CAP., AEL 2200UF 10V 105 DEGREE C	310033-27
C116	CAP., AEL 220MF 25V	310004-21
C117	CAP., AEL 220MF 25V	310004-21
C118	CAP., CD 1000PF 500V	320036-37
C119	CAP., CD 1000PF 500V	320036-37
C120	CAP., MG .1MF 50V AXIAL	320001-25
C121	CAP., MG .1MF 50V AXIAL	320001-25

Table 5-2 Terminal PCB Components List, Continued

Reference Designator	Description	Part
C122	CAP., MG .1MF 50V AXIAL	320001-25
C123	CAP., MG .1MF 50V AXIAL	320001-25
C124	CAP., MG .1MF 50V AXIAL	320001-25
C125	CAP., MG .1MF 50V AXIAL	320001-25
C126	CAP., CDZ 1800PF 20% 250VAC Z5U 3/8LS	320050-04
C127	CAP., CDZ 1800PF 20% 250VAC Z5U 3/8LS	320050-04
C201	CAP., PEE .022MF 50V 5%	320501-10
C202	CAP., AEL 1MF 50V	310006-07
C203	CAP., PPN .015UF 400V J	320525-09
C204	CAP., CD .001MF 50V	320030-37
C205	CAP., ASN 3.3UF 35V M 85 DEGREE C	310027-10
C206	CAP., MPF .22MFD 100V	320510-17
C207	CAP., CD 330PF 500V K Y5P	320036-31
C208	CAP., AEL 470MF 16V VT. MNT.	310003-23
C209	CAP., AEL 220MF 35V VT. MNT.	310005-21
C210	CAP., CD .01MF 1KV	320046-49
C211	CAP., AEL 100MF 63V	310007-19
C212	CAP., AEL 10MF 160V	310132-13
C213	CAP., CD .01MF 1KV	320046-49
C214	CAP., CD 1000PF 1KV Z	320040-37
C215	CAP., CD 1000PF 500V	320036-37
C216	CAP., MG .1MF 50V AXIAL	320001-25
C217	CAP., MG .01MF 50V (AXIAL)	320001-13
C218	CAP., MG .01MF 50V (AXIAL)	320001-13
C301	CAP., CD 100PF 50V K Y5P	320030-25
C302	CAP., MPF .1MFD 100V	320505-15
C303	CAP., MPF .1MFD 100V	320505-15
C304	CAP., MPF .1MFD 100V	320505-15
C305	CAP., CD 1500PF 50V 10%	320030-39
C306	CAP., AEL 22MF 25V	310004-15
C307	CAP., MPF .1MFD 100V	320505-15
C308	CAP., CD 560PF 500V 10%	320036-34
C309	CAP., AEL 100MF 16V	310003-19
C310	CAP., AEL 2200MF 16V	310003-27
C311	CAP., AEL 100MF 16V	310003-19
C312	CAP., CD 4700PF 50V K Y5P	320030-45
C401	CAP., CD .22MF 50V	320004-29
C402	CAP., MK 150PF 50V J NPO	80-960-06
C403	CAP., CD .01MF 500V -20%+80%	320037-49
C404	CAP., CD .22MF 50V	320004-29
D1	DIODE, 1N4148	280001-01
D2	DIODE, 1N4148	280001-01
D3	D.ZENER HZ6C2(SUB:80-170-12)	80-170-69
D4	D.ZENER HZ6C2(SUB:80-170-12)	80-170-69
D5	D.ZENER HZ6C2(SUB:80-170-12)	80-170-69
D101	DIODE, 1N5397	283203-01
D102	DIODE, 1N5397	283203-01
D103	DIODE, 1N5397	283203-01
D104	DIODE, 1N5397	283203-01

Table 5-2 Terminal PCB Components List, Continued

Reference Designator	Description	Part
D105	DIODE, RGP5020	283703-02
D106	DIODE, IN4937 1A/600V	283701-01
D107	DIODE, IN4937 1A/600V	283701-01
D108	DIODE, RGP30G	283704-01
D109	D., SB350 3A/50V SCHOTTKY	282202-01
D110	DIODE, IN4937 1A/600V	283701-01
D113	DIODE, IN4937 1A/600V	283701-01
D114	RECT, RGP10M FST RCVY 1KV	283714-01
D201	DIODE, U19C	283707-01
D202	DIODE, V19E	283715-01
D203	DIODE, V11N	283710-01
D204	DIODE, V09C	283702-01
D205	DIODE, V09C	283702-01
D301	DIODE, V09C	283702-01
D302	DIODE, IN4148	280001-01
D401	DIODE, IN4148	280001-01
D402	D.ZENER HZ6C2 (SUB:80-170-12)	80-170-69
D403	DIODE, IN4148	280001-01
D404	DIODE, ZENER HZ3B2	281305-11
D405	DIODE, ZENER HZ3B2	281305-11
D406	DIODE, IN4148	280001-01
D407	DIODE, IN4148	280001-01
D408	DIODE, IN914B	280000-01
F101	FUSE HOLDER, HORIZONTAL MOUNT	532002-01
IC102	IC ADJUST SHUNT REGULATOR (TL431C)	221004-01
IC301	IC TDA 1170N	222504-01
IC101	IC 4N35	290000-01
Q101	TRANSISTOR, 2SC2979	272018-01
Q102	TRANSISTOR, (MOTOROLA 2N2222)	270000-01
Q201	TRANSISTOR, 2SC1213	270018-01
Q202	TRANSISTOR, BU406	272000-01
Q203	TRANSISTOR, 2SA844/2SA733	270503-01
Q301	TRANSISTOR, (MOTOROLA 2N2222)	270000-01
Q401	TRANSISTOR, 2N2369	270001-01
Q402	XSTR, MRF531, NPN, 100V, 800MHZ, 2.5W	270025-01
Q403	TRANSISTOR, (MOTOROLA 2N2222)	270000-01
Q404	TRANSISTOR, (MOTOROLA 2N2222)	270000-01
R1	RES, CF 470 OHM 1/4W 5%	370001-65
R2	RES, CF 360 OHM 1/4W 5%	370001-62
R4	RES, CF 470 OHM 1/4W 5%	370001-65
R5	RES, CF 360 OHM 1/4W 5%	370001-62
R7	RES, CF 2.2K OHM 1/4W 5%	370001-81
R9	RES, CF 5.6K 1/4W 5%	370001-91
R10	RES, CF 2.2K OHM 1/4W 5%	370001-81
R12	RES, CF 4.7K OHM 1/4W 5%	370001-89
R13	RES, CF 2.2K OHM 1/4W 5%	370001-81

Table 5-2 Terminal PCB Components List, Continued

Reference Designator	Description	Part
R14	RES, CF 4.7K OHM 1/4W 5%	370001-89
R16	RES, CF 4.7K OHM 1/4W 5%	370001-89
R17	RES, CF 10K OHM 1/4W 5%	370002-01
R18	RES, CF 12K OHM 1/4W 5%	370002-03
R19	RES, CF 12K OHM 1/4W 5%	370002-03
R20	RES, CF 4.7K OHM 1/4W 5%	370001-89
R21	RES, CF 4.7K OHM 1/4W 5%	370001-89
R22	RES, CF 12K OHM 1/4W 5%	370002-03
R23	RES, CF 2K OHM 1/4W 5%	370001-80
R24	RES, CF 2K OHM 1/4W 5%	370001-80
R25	RES, CF 62 OHM 1/4W 5%	370001-44
R26	RES, CF 62 OHM 1/4W 5%	370001-44
R27	RES, CF 68 OHM 1/4W 5%	370001-45
R28	RES, CF 62 OHM 1/4W 5%	370001-44
R29	RES, CF 100 OHM 1/4W 5%	370001-49
R30	RES, CF 62 OHM 1/4W 5%	370001-44
R31	RES, CF 10 OHM 1/4W 5%	370001-25
R101	RES, CF 330K 5% 1W	370006-37
R102	RES, MOF 33 OHM 2W 5%	370605-61
R103	RES, MOF 1K OHM 5W 5%	370610-38
R104	RES, CF 68 OHM 1/4W 5%	370001-45
R105	RES, WW 1.5 OHM 3W 5%	370903-29
R106	RES, CF 33 OHM 1/4W 5%	370001-37
R107	RES, CF 4.7K OHM 1/4W 5%	370001-89
R108	RES, CF 12K OHM 1/4W 5%	370002-03
R109	RES, CF 1.5K OHM 1/4W 5%	370001-77
R110	RES, CF 15K OHM 1/4W 5%	370002-05
R112	RES, CF 1K OHM 1/4W 5%	370001-73
R113	RES, CF 10 OHM 1/2W 5%	370003-25
R114	RES, CF 120K OHM 1/2W 5%	370004-27
R115	RES, CF 120K OHM 1/2W 5%	370004-27
R116	RES, CF 10 OHM 1/2W 5%	370003-25
R118	RES, WW 3.9 OHM 3W 5%	370903-39
R201	RES, CF 470 OHM 1/4W 5%	370001-65
R202	RES, CF 56 OHM 1/4W 5%	370001-43
R203	RES, MOF 33 OHM 1W 5%	370603-61
R204	RES, MOF 560 OHM 1W 5%	370603-91
R205	RES, CF 150K OHM 1/4W 5%	370002-29
R206	RES, CF 120K OHM 1/4W 5%	370002-27
R207	RES, CF 220K OHM 1/2W 5%	370004-33
R208	RES, CF 220K OHM 1/2W 5%	370004-33
R209	RES, CF 1 MEG, 1/4W 5%	370002-49
R210	RES, CF 68K OHM 1/4W 5%	370002-21
R211	RES, CF 10K OHM 1/4W 5%	370002-01
R212	RES, CF 3K OHM 1/4W 5%	370001-84
R213	RES, CF 22K OHM 1/4W 5%	370002-09
R214	RES, CF 10 OHM 1/4W 5%	370001-25
R215	RES, CF 2.2K OHM 1/4W 5%	370001-81
R216	RES, CF 10 OHM 1/2W 5%	370003-25
R217	RES, CF 100 OHM 1/4W 5%	370001-49

Table 5-2 Terminal PCB Components List, Continued

Reference Designator	Description	Part
R301	RES, CF 10K OHM 1/4W 5%	370002-01
R302	RES, CF 250K 5% 1/4W	370002-68
R303	RES, CF 180K OHM 1/4W 5%	370002-31
R304	RES, CF 1 MEG, 1/4W 5%	370002-49
R305	RES, CF 47K OHM 1/4W 5%	370002-17
R306	RES, CF 39K OHM 1/4W 5%	370002-15
R307	RES, CF 4.7K OHM 1/4W 5%	370001-89
R308	RES, CF 1 OHM 1/2W 5%	370003-01
R309	RES, CF 5.6K 1/4W 5%	370001-91
R310	RES, CF 4.7K OHM 1/4W 5%	370001-89
R311	RES, CF 3.3 OHM 1/4W 5%	370001-13
R312	RES, CF 220K OHM 1/4W 5%	370002-33
R313	RES, CF 75 OHM 1/4W 5%	370001-46
R314	RES, CF 390K OHM 1/4W 5%	370002-39
R315	RES, CF 2.2K OHM 1/4W 5%	370001-81
R401	RES, CF 120 OHM 1/4W 5%	370001-51
R402	RES, CF 47 OHM 1/4W 5%	370001-41
R403	RES, CF 680 OHM 1/4W 5%	370001-69
R404	RES, CF 47 OHM 1/4W 5%	370001-41
R405	RES, CF 51 OHM 1/4W 5%	370001-42
R406	RES, CF 27 5% 1/4W AXL	370001-35
R407	RES, CF 470 OHM 1/4W 5%	370001-65
R408	RES, MOF 1K OHM 2W 5%	370606-01
R409	RES, CF 220 OHM 1/4W 5%	370001-57
R410	RES, CF 47 OHM 1/4W 5%	370001-41
R411	RES, CF 5.6K 1/4W 5%	370001-91
	XFRMR, DPLUS FOCUS	429006-01
L1	RES, CF 10 OHM 1/4W 5%	370001-25
L2	RES, CF 10 OHM 1/4W 5%	370001-25
L3	RES, CF 10 OHM 1/4W 5%	370001-25
L4	RES, CF 10 OHM 1/4W 5%	370001-25
L101	XFMR, WY60 LINE FLTR	424506-01
L104	COIL, 10UH CHOKE	410502-01
L102	COIL, CHOKE 10UH 1.5A	410500-02
L103	COIL, CHOKE 10UH 1.5A	410500-02
L201	COIL, DPLUS HORIZ. LINEAR	411011-01
L202	COIL, HOR. WIDTH	413500-01
S101	SWITCH, A/C SPST YELLOW LEGEND	341503-01
	TRANSFORMER, POWER	421517-01
T102	TRANSFORMER, DRIVE	420029-01
T201	TRANSFORMER, HOR. DRIVE	423019-01
T202	XFRMR, DPLUS FLBCK	420016-01
U1	IC, 8051AH UCOMP 8BIT MASK ROM 40P	202008-01
U2	IC, 2404 EEPROM(4096 BIT) 8P	194011-01
U3	IC, 2661-B	205501-01
U4	IC, 74LS373	170093-01

Table 5-2 Terminal PCB Components List, Continued

Reference Designator	Description	Part
U5	IC, 74LS138	170043-01
U7	IC, HM6264P-12 CMOS SRAM 8KX8	192004-01
U8	IC, HM6264P-12 CMOS SRAM 8KX8	192004-01
U9	IC, 2672 PRG,VDO TIMG CONT 4.6HZ 40P	205001-02
U10	IC, 74LS245	170075-01
U11	IC, 74LS245	170075-01
U12	IC, 74LS245	170075-01
U13	IC, 74LS374	170094-01
U14	IC, 74LS374	170094-01
U15	IC, 2128L SRAM(2KX8) 120NS 24P	192001-01
U16	IC, 2128L SRAM(2KX8) 120NS 24P	192001-01
U17	IC, 74LS273	170083-01
U18	IC, 74LS374	170094-01
U19	IC, HM6264P-12 CMOS SRAM 8KX8	192004-01
U21	IC, 74S00 4X 2INPUT NAND	170112-12
U22	IC, 74LS04	170003-01
U23	IC, 74LS368	170092-01
U24	IC, 74LS00	170112-01
U25	IC, 1489A	226001-01
U26	IC, 1488	226000-01
U27	IC, 1488	226000-01
U28	IC, 1489A	226001-01
	IC, DPLUS GATE ARRAY REV B	211003-02
VR101	RES., VAR. 1K OHM	360007-05
VR201	RES., VAR. 2M-B	360009-18
VR202	RES., VAR. 200 K-B	360007-13
VR204	RES., VAR. 100K M VZ084THZ	360002-12
VR205	RES., VAR. 5K OHM LINEAR	360006-07
VR302	RES., VAR. 200 K-B	360007-13
VR303	RES., VAR. 100K-B	360007-12
VR401	RES., VAR. 500 OHM LINEAR	360006-04
X1	XTAL, 26.58MHZ .005% HC49/18U SER	390000-44
X2	XTAL, 39.710MHZ .005% HC49/18U SER	390000-47
X3	CRYSTAL, 4.9152 MHZ	390000-11
X4	CRYSTAL, 11.000 MHZ	390000-24

Figure 5-4 Terminal Board Assembly Layout

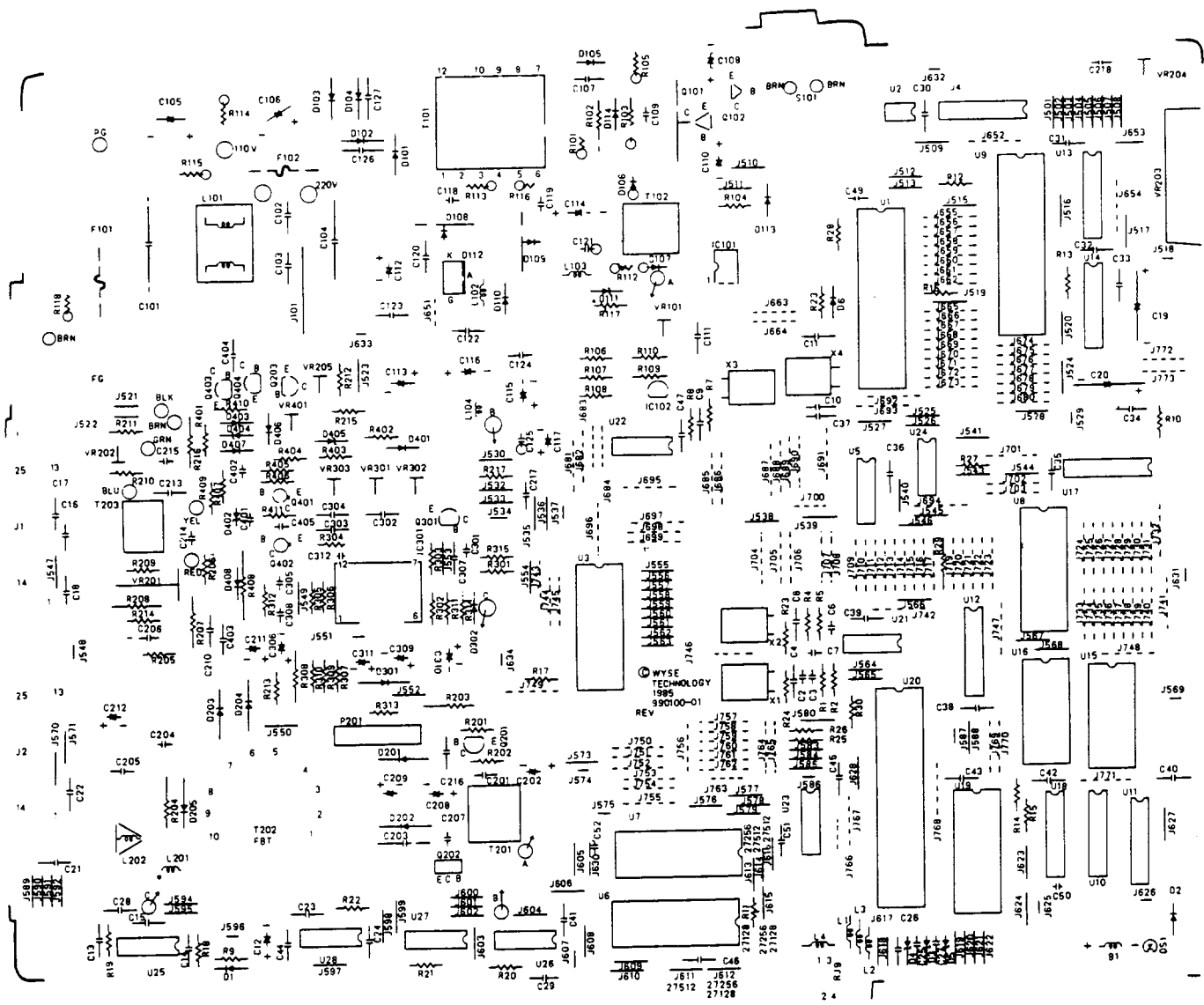

Table 5-3 WY-60 ASCII Keyboard PCB Components List

Reference Designator	Description	Part
C1	CAP., MG .1MF 50V AXIAL	320001-25
C2	CAP., AEL 47MF 10V	310002-17
C3	CAP., MG .0015MF 50V	80-960-05
C4	CAP., MG .1MF 50V AXIAL	320001-25
D1	DIODE, 1N914B	280000-01
D2	DIODE, 1N914B	280000-01
D3	DIODE, ZENER HZ6C2	80-170-69
D4	DIODE, 1N914B	280000-01
D5	DIODE, 1N914B	280000-01
D6	DIODE, 1N914B	280000-01
D7	DIODE, 1N914B	280000-01
R1	RES., CF 10 OHM 1/4W 5%	370001-25
R2	RES., CF 10 OHM 1/4W 5%	370001-25
R3	RES., CF 10 OHM 1/4W 5%	370001-25
R4	RES., CF 10 OHM 1/4W 5%	370001-25
R5	RES., CF 24K OHM 1/4W 5%	370002-10
U1	IC, KEYBOARD GATE ARRAY CHIP	211001-01

Figure 5-5 WY-60 ASCII Keyboard PCB Layout

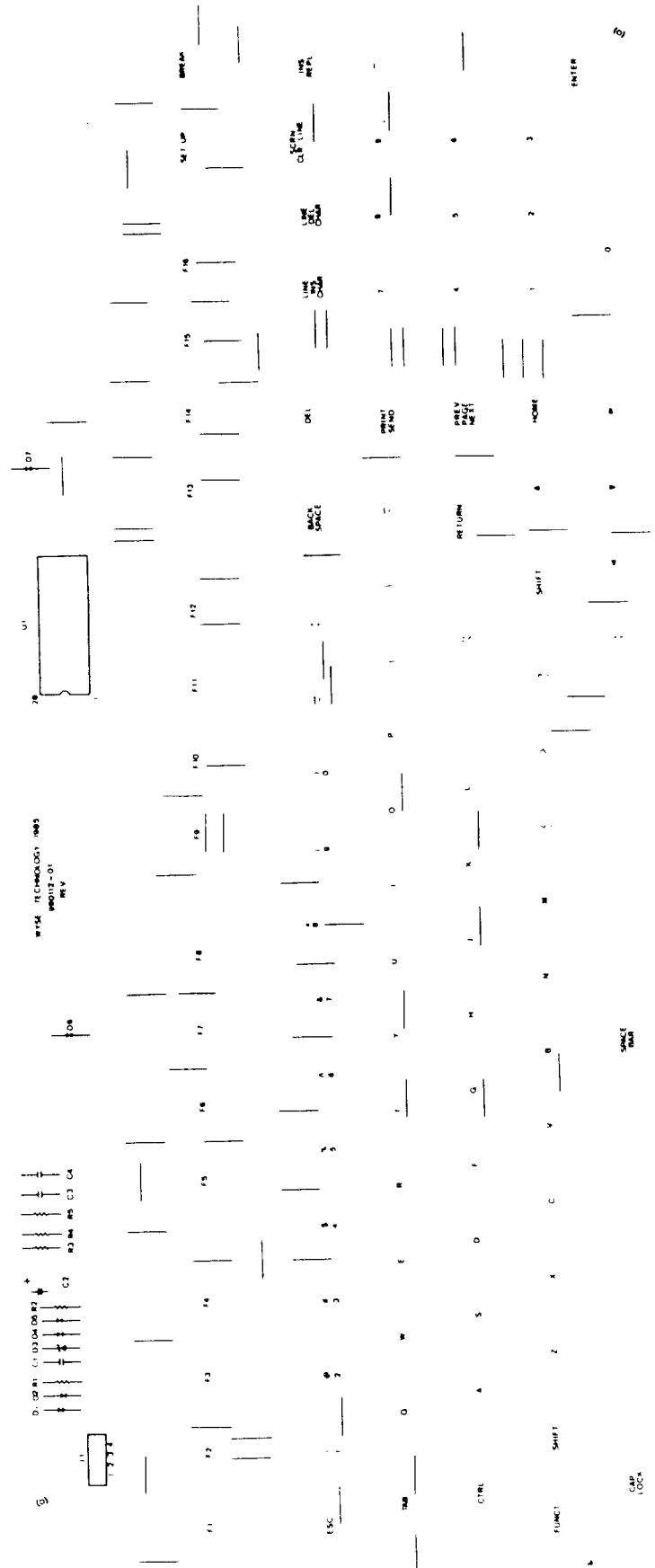
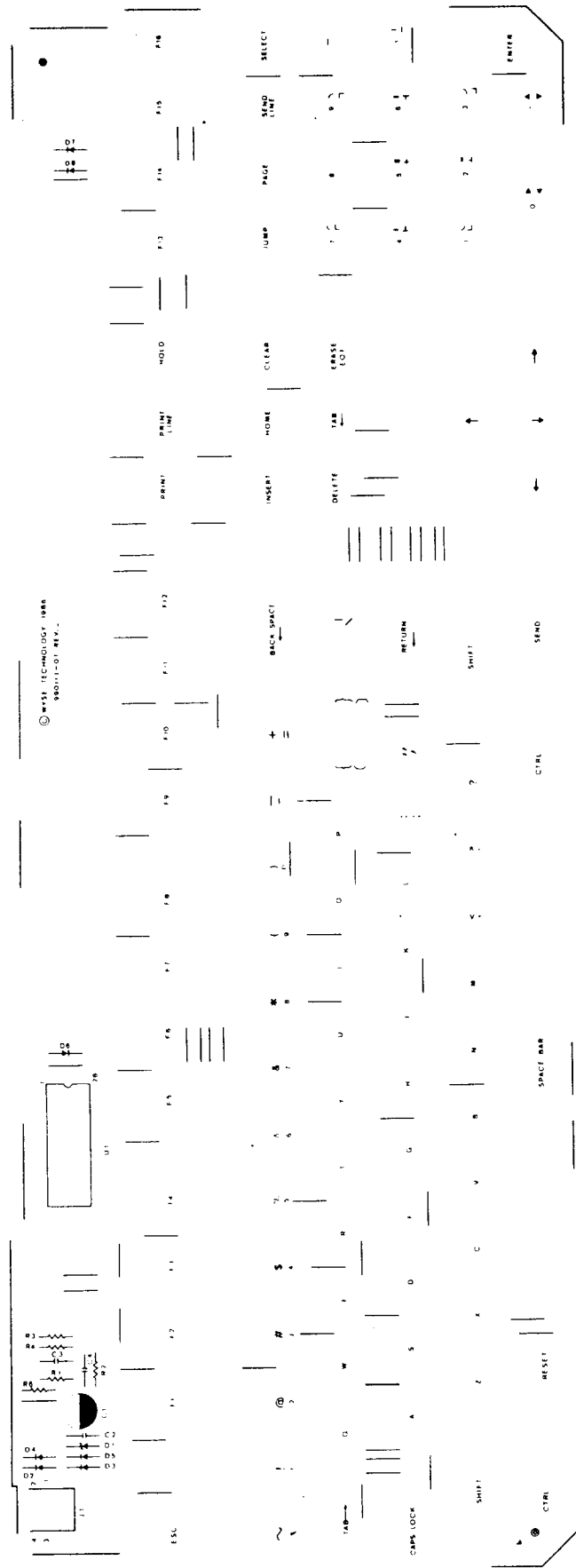

Table 5-4 316X-Style Keyboard PCB Components List

Reference Designator	Description	Part
C1	CAP., AEL 470MF 6.3V	310001-23
C2	CAP., MG .1MF 50V AXIAL	320001-25
C3	CAP., MG .0015MF 50V	80-960-05
C4	CAP., MG .1MF 50V AXIAL	320001-25
D1	DIODE, ZENER HZ6C2	80-170-69
D2	DIODE, 1N914B	280000-01
D3	DIODE, 1N914B	280000-01
D4	DIODE, 1N914B	280000-01
D5	DIODE, 1N914B	280000-01
D6	DIODE, 1N914B	280000-01
D7	DIODE, 1N914B	280000-01
D8	DIODE, 1N914B	280000-01
R1	RES., CF 20 OHM 1/WW 5%	370001-32
R2	RES., CF 20 OHM 1/WW 5%	370001-32
R3	RES., CF 10 OHM 1/4W 5%	370001-25
R4	RES., CF 24K OHM 1/4W 5%	370002-10
R6	RES., CF 10 OHM 1/4W 5%	370001-25
U1	IC, KEYBOARD GATE ARRAY CHIP	211001-01
None	SWITCH, KEY	340007-01

Figure 5-6 316X-Style Keyboard PCB Layout



For Service Manuals
MAURITRON SERVICES
 8 Cherry Tree Road, Chinnor
 Oxfordshire, OX9 4QY.
 Tel (01844) 351694
 Fax (01844) 352554
 email:- mauritron@dial.pipex.com

Table 5-5 AT-Style Keyboard PCB Components List

Reference Designator	Description	Part
C1	CAP., AEL 470MF 6.3V	310001-23
C10	CAP., MG .1MF 50V AXIAL	320001-25
C2	CAP., MG .1MF 50V AXIAL	320001-25
C3	CAP., MG .0015MF 50V	80-960-05
C4	CAP., MG .1MF 50V AXIAL	320001-25
C5	CAP., MG .1MF 50V AXIAL	320001-25
C6	CAP., MG .1MF 50V AXIAL	320001-25
C7	CAP., MG .1MF 50V AXIAL	320001-25
C8	CAP., MG .1MF 50V AXIAL	320001-25
C9	CAP., MG .1MF 50V AXIAL	320001-25
D1	DIODE, IN914B	280000-01
D2	DIODE, IN914B	280000-01
D3	DIODE, IN914B	280000-01
D4	DIODE, IN914B	280000-01
D5	DIODE, IN914B	280000-01
D6	DIODE, ZENER 6.2V 1/2W	281305-08
D7	DIODE, ZENER 6.2V 1/2W	281305-08
D8	DIODE, ZENER 6.2V 1/2W	281305-08
Q1	TRANSISTOR, 2N2907	270500-02
Q2	TRANSISTOR, 2N2907	270500-02
Q3	TRANSISTOR, 2N2907	270500-02
R1	RES., CF 2.2K OHM 1/4W 5%	370001-81
R10	RES., CF 10K OHM 1/4W 5%	370002-01
R11	RES., CF 10K OHM 1/4W 5%	370002-01
R2	RES., CF 24K OHM 1/4W 5%	370002-10
R3	RES., MF 100 OHM 1/4W 5%	370344-49
R4	RES., MF 100 OHM 1/4W 5%	370344-49
R5	RES., MF 100 OHM 1/4W 5%	370344-49
R6	RES., CF 10 OHM 1/4W 5%	370001-25
R7	RES., CF 10 OHM 1/4W 5%	370001-25
R8	RES., CF 10 OHM 1/4W 5%	370001-25
R9	RES., CF 10K OHM 1/4W 5%	370002-01
U1	IC, KEYBOARD GATE ARRAY CHIP	211001-01

Figure 5-7 AT-Style Keyboard PCB Layout

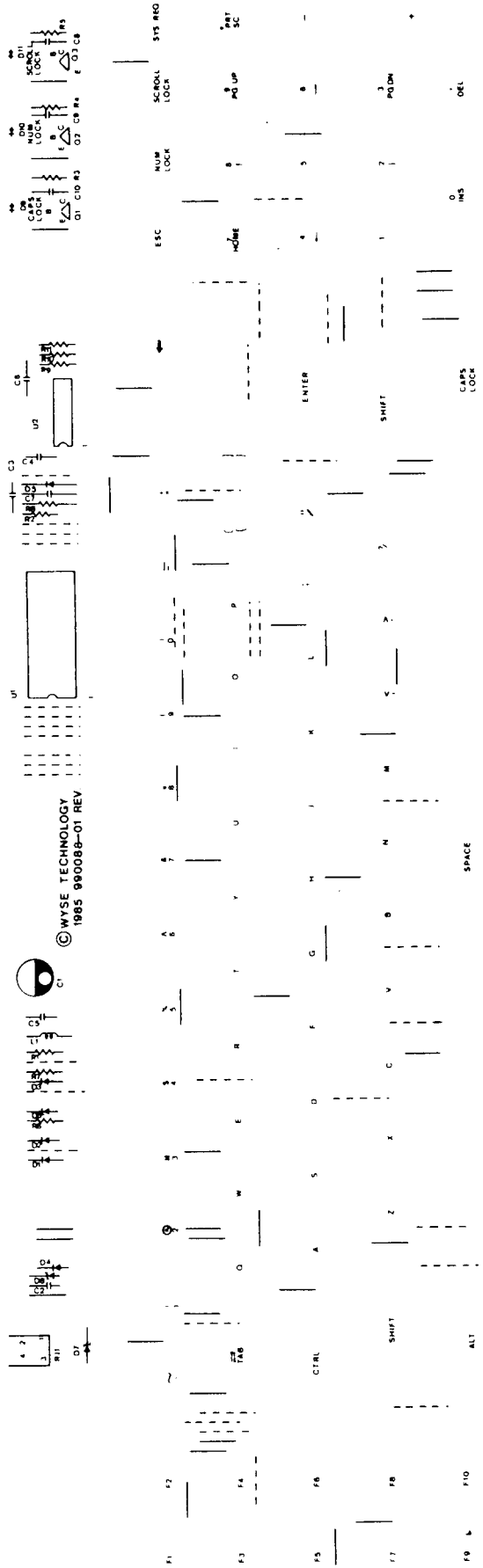

Table 5-6 Diagnostic Tools

Part	Part Number
Connector set	940268-01
MODEM port connector	940270-01
AUX port connector	940267-01

6 THEORY OF OPERATIONS

Terminal PCB Logic Components Functional Description	6-1
Monitor/Power Supply Components Functional Description	6-6
Keyboard	6-8
Additional Functional Descriptions	6-9
Microcontroller	6-9
Communication Interface	6-10
Display Memory	6-11
Nonvolatile Memory	6-11
Keyboard Interface	6-11
Video Control	6-11
Raster Scan Terminology	6-13

Note--If you are unfamiliar with raster scan techniques, read the brief explanation of raster scan terms at the end of the chapter.

TERMINAL PCB LOGIC COMPONENTS FUNCTIONAL DESCRIPTION

This section contains a functional description and reference designator for each significant component of the logic circuitry on the terminal PCB (see Figure 6-1).

Figure 6-1 Terminal PCB Logic Circuitry Functional Block Diagram

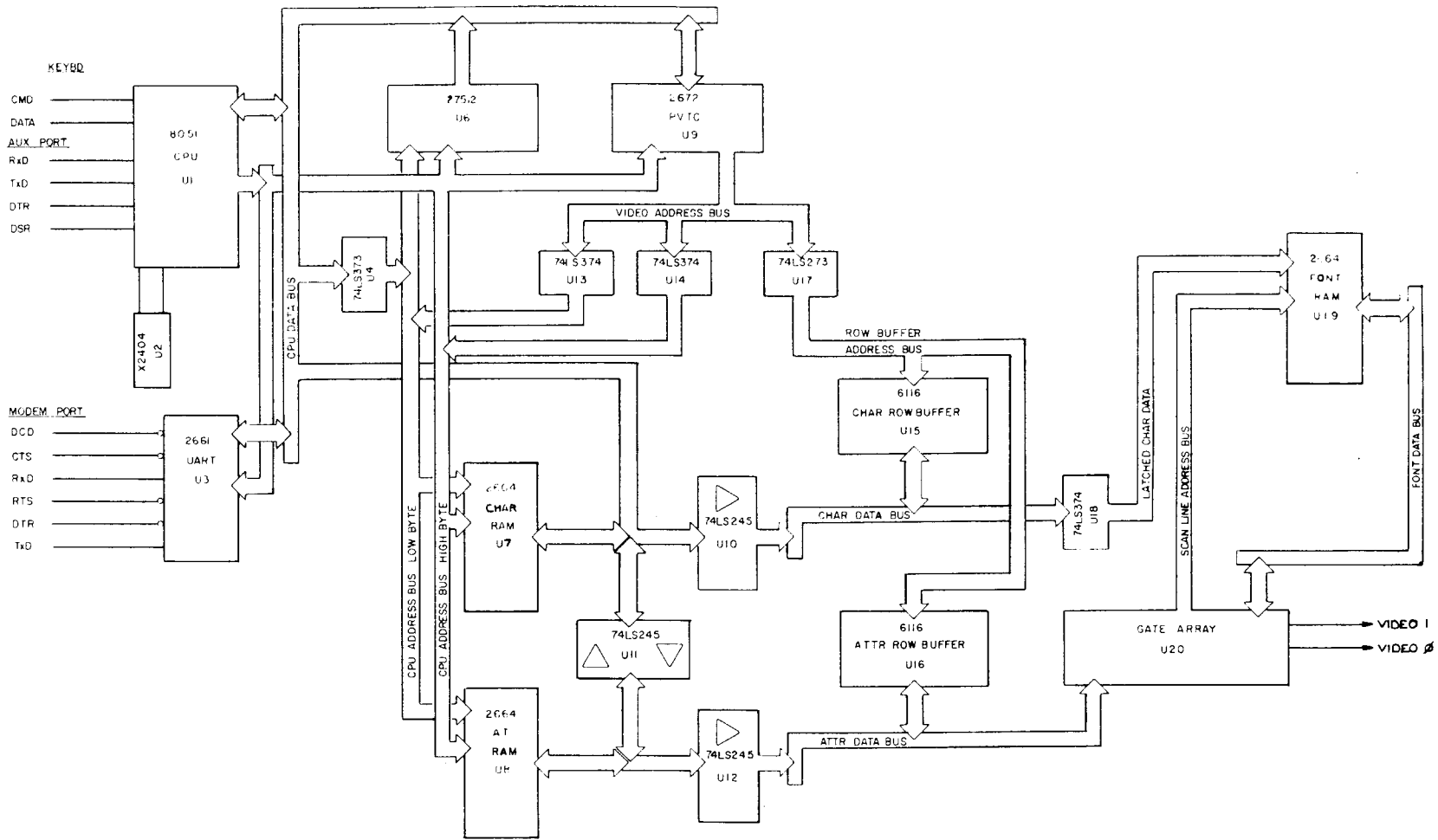

8051 Microprocessor (U1)--The terminal has a single-component control-oriented microprocessor which contains 256 bytes of random-access memory (RAM), 16 input/output (I/O) lines, three 16-bit counter/timers, and a universal asynchronous receiver/transmitter (UART). It has integral interrupt and clock circuitry. The microcontroller uses eight data lines multiplexed with the lower eight address lines. Address information appears on these lines only when the address latch enable (ALE) signal is present. The upper address lines (A8-A15) are nonmultiplexed single-direction lines. The internal UART is used for the AUX printer port.

Gate Array(U20)--The gate array contains the functions described below:

Beeper Driver--The gate array contains a driver that enables a beep. The beep frequency is HSYNC divided by 20.

Attribute data latches--The attribute data latches store both screen and row attributes for each character to be displayed, one at a time, for the attribute generation circuitry. Examples of screen attributes include foreground brightness and blink rate. Examples of row attributes include scan line count, double high, and double wide.

Video shift register--The output of the character generator is an 8-bit parallel code. The raster scanned CRT is a serial device. The parallel-to-serial converter converts the parallel output of the character generator into a serial format the CRT can use.

Video drivers and dot stretcher--Video drivers allow output from the parallel-to-serial converter to interface with the CRT. In addition, the dot stretcher extends the on time of video dots so that single vertical rows of dots appear to have the same intensity as strings of horizontal dots. The blanking signal disables the driver so that the video output is inhibited during vertical and horizontal retrace.

Soft-font control--The gate array contains circuitry to control soft-font loading and generates soft-font selection signals.

Pre-settable scan line counter--The gate array enables smooth scrolling with the pre-settable scan line counter.

Clock generator--The gate array generates timing signals for the CRT controller.

Blink rate generator--The gate array generates blink rate signals for both characters and cursor.

Clock Divider--The 8051 selects the oscillator frequency that goes to the gate array. The gate array divides these frequencies to generate specific clock rates. Table 6-1 lists original dot clock rate (oscillator frequencies), number divided by, the rate it becomes after division, and what it controls.

Table 6-1 Clock Rates

Beginning Clock Rate	Divisor	New Clock Rate	New Clock
39.710 MHz	9	4.4122 MHz	CCLK (132-column mode)
26.580 MHz	10	2.658 MHz	CCLK (80-column mode)

Programmable video timing controller (U9)--The microcontroller initializes the programmable video timing controller (PVTC) during power-up. The CRT controller interfaces with the video display memory (RAM) on a direct-memory access (DMA) basis. Display data then moves to the character generation circuitry for processing. The CRT controller chip (PVTC) generates the cursor and also provides the necessary timing and control information for the display logic: horizontal synchronization, vertical synchronization, and blank.

UART (U3)--The universal asynchronous receiver/transmitter (UART) takes parallel data from the microprocessor and converts it to a bit-serial format for external communication equipment through the MODEM port. In addition, the UART converts bit-serial information received from an external source to parallel information for the microprocessor. The UART flags the microcontroller with an interrupt when it needs service.

Code ROM (U6)--The code ROM is nonvolatile memory for program storage. All routines reside in ROM. The terminal ROM can be either 32 or 64K bytes (60KB maximum available for storage), depending upon PROM type, either the 27256 or 27512. The ROM does not reside within the RAM memory map because it has a unique enable line (PSEN).

Chip select decoder (U5)--The chip select decoder decodes the higher order address bits (A13, A14, A15) and the Read and Write control lines (RD and WR) from the microcontroller. The decoder generates enable signals for the character RAM, UART, and PVTC.

Low order address latch (U4)--This IC latches and gates the lower order address information from the microcontroller when activated by the microcontroller's address latch enable (ALE) signal. The latch separates data from the address bus when data is present on the microcontroller's multiplexed lower address and data bus interface.

Keyboard interface (U23)--The microprocessor communicates with the keyboard on two lines. It checks to see if a key has been pressed on the keyboard by addressing the key matrix with the keyclock signal (CMD), then examining the keyboard return line (DATA) on the data bus. The microcontroller looks for the positive key return on port one, bit six.

Row buffer RAM (U15, U16)--The row buffer RAMs hold, in order, character codes and attribute information for the current row being displayed or refreshed. RAM U15 holds character codes. RAM U16 holds attribute information.

Video address latches (U13, U14)--The video address buffers hold address information sent from the PVCT until \overline{BREQ} goes high and signals the CPU off the data bus. When the data bus is clear, the video address buffers send the addresses to the display RAMs U7 and U8.

Character and Attribute RAM (U7, U8)--The logic circuitry contains two 8Kx8 static RAMs. One of the RAMs stores character data, while the remaining RAM stores attribute data, for hidden (non-embedded) and embedded attributes. Attribute memory locations are addressed automatically each time character memory is addressed. This allows the 8-bit microprocessor to read and write 16-bit words.

Character row buffer data latch (U18)--The character row buffer data latch stores each character to be displayed (one at a time) for the character generation circuitry.

Font RAM (U19)--This 8Kx8 RAM stores character data for the fonts. Two bits set in the attribute byte select each of the four fonts in this RAM. The 8051 selects the font and sends this information to the gate array. At power-on, the gate array loads font information into the font RAM.

Dot clock oscillator (U21)--The dot clock oscillator consists of two crystal oscillators: 26.580 MHz for 80-column mode and 39.710 MHz for 132-column mode. The 8051, port 1, bit 0, controls oscillator selection. The oscillator output is the dot clock rate.

Nonvolatile memory (U2)--The nonvolatile memory consists of an EEPROM. This memory stores setup parameters such as baud rate and parity. The EEPROM retains its data until reprogrammed. It connects directly with 8051 ports P1.1 (data) and P1.2 (clock).

Level converters (EIA to TTL) (U25, U28)--These level converters change the EIA RS-232C logic levels to TTL levels for the UART.

Level converters (TTL TO EIA) (U26, U27)--These level converters change the TTL logic levels from the UART to RS-232C to communicate with external equipment.

UART clock (U22)--The UART clock generator consists of a 4.9152 MHz crystal connected to the XTAL inputs of the UART. The UART has its own internal clock circuitry that divides the basic crystal into baud rates for the UART. The user programs the UART in setup for the appropriate baud rate.

MONITOR/POWER SUPPLY COMPONENTS FUNCTIONAL DESCRIPTION

The terminal PCB also contains both monitor and power supply circuitry. The power supply provides the voltages for all the logic. The monitor circuitry controls the video image on the CRT screen. Figure 6-2 is a functional block diagram of the monitor and power supply circuitry. Note that each block is numbered. This number corresponds with the item number in the following descriptions.

Line filter (1)--The line filter attenuates noise from the external power source (the AC power cord and wall socket). It also filters any noise produced by the switching power supply to comply with FCC regulations.

Voltage doubler (2)--The terminal operates with either a 115 VAC or 230 VAC input. The voltage doubler circuit provides 270 to 300 VDC for the oscillator circuit when 115 VAC is applied, and is passive when the 230 VAC input strap is installed. This assures that the oscillator (DC to AC converter) always has a 270 to 300 VDC input regardless of the AC input voltage.

Pulse width modulator(PWM) (3)--The PWM consists of a pair of switching transistors. It sends AC input voltage to the main power transformer. The PWM is synchronized with the horizontal synchronization pulses to eliminate beat frequencies.

Main switching power transformer (4)--The main power transformer provides taps for each power supply.

Horizontal driver (5)--The horizontal driver makes sure that the yoke is driven at the correct frequency so that the electron beam sweeps from left to right at the correct rate. It also provides the signal to drive the flyback transformer.

Regulation circuitry (6)--The regulation circuitry measures the +5 and +12 volt supplies. It generates an error voltage proportional to any error it may find when measuring the supplies. Optically coupling the error signal with the pulse width modulator which controls its duty cycle regulates the output voltage of the main switching power transformer.

+5 volt supply (7)--The +5V is derived directly from one of the main transformer taps which provides low voltage AC. The output of this tap is rectified and regulated.

Figure 6-2
Diagram

Monitor/Power Supply Circuitry Functional Block

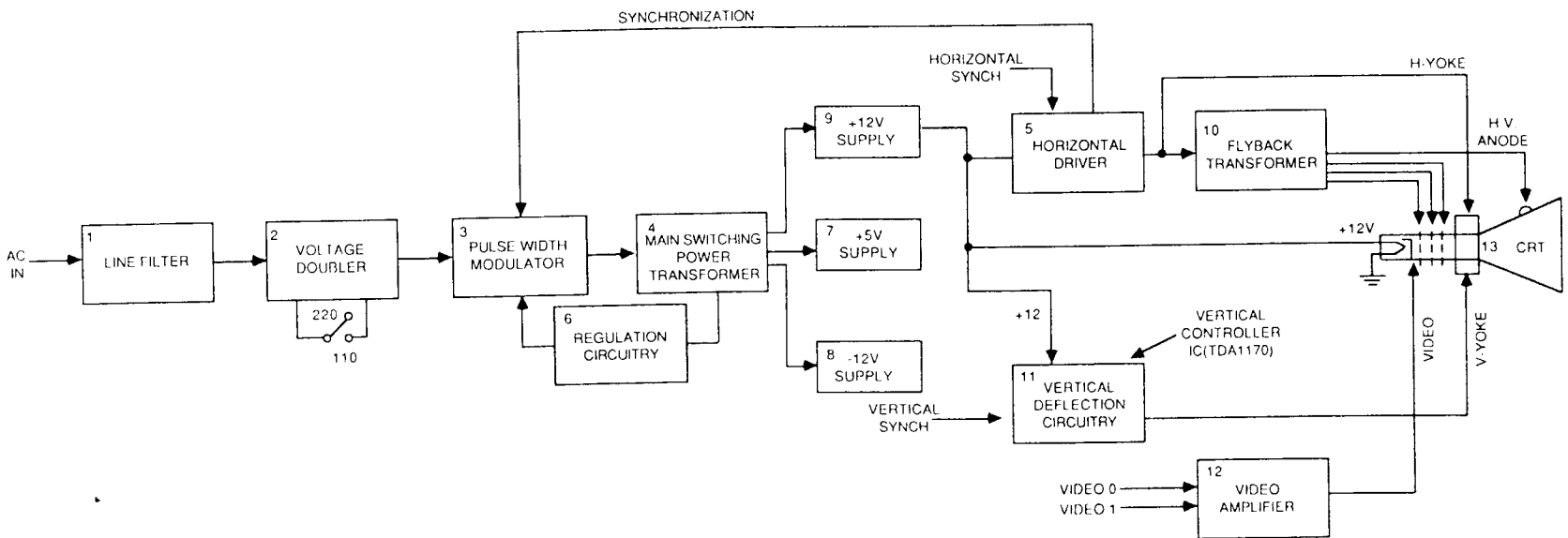

-12 volt supply (8)--The -12V supply is derived from one of the main transformer taps. The low voltage AC output is rectified and filtered. The -12 volt supply is V_{EE} for the RS-232 drivers.

+12 volt supply (9)--The +12 supply is derived from one of the main transformer taps. The low voltage AC output is rectified and filtered. This supply provides filament voltage and V_{CC} for U26 and U27.

Flyback transformer (10)--The flyback transformer steps up the output of the horizontal driver to provide the high voltage for the CRT itself. In addition, the flyback transformer generates +50 volts for the video amplifier, the +600 focus voltage, and the brightness bias voltage (-100 VDC).

Vertical deflection circuit (11)--The vertical deflection circuit provides the yoke with the correct vertical drive frequency to ensure that the electron beam scans the face of the CRT at the correct vertical repetition rate. This circuit also controls display height and linearity.

Video amplifier (12)--The video amplifier varies the voltage on the CRT cathode, pin 2. This modulates the beam current. Higher beam current causes a brighter spot on the screen.

CRT (13)--The CRT displays data by receiving a modulated electron beam with the video signal while the beam moves across the face of the screen. The horizontal and vertical drive signals determine the rate of movement.

KEYBOARD

Figure 6-3 is a block diagram of the keyboard.

Figure 6-3 Keyboard Block Diagram

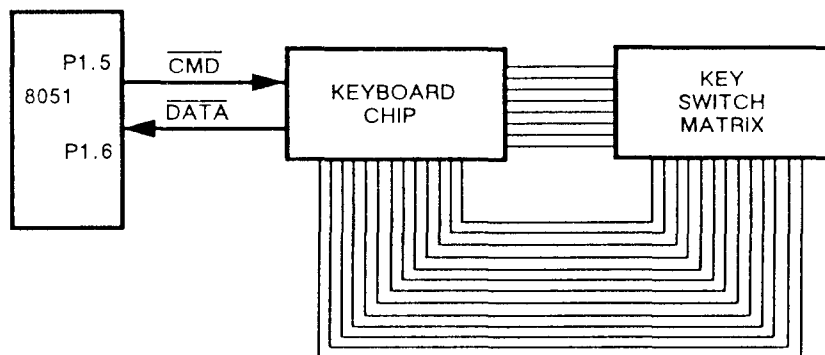

The keyboard PCB is arranged as a matrix of up to 13 rows of eight columns each. Each key switch connects one row to one column when that key is pressed. The keyscanner interface chip has 13 opendrain row outputs and eight column inputs with active pullups. The integrated circuit communicates with the external processor on two lines: the command line (\overline{CMD}) and the data line (\overline{DATA}).

ADDITIONAL FUNCTIONAL DESCRIPTIONS

The logic circuitry on the terminal PCB consists of six sections: microcontroller, communications interface, display memory, nonvolatile memory, keyboard interface, and video control.

Microcontroller

The 8051 is a control-oriented microcontroller that contains 256 bytes of RAM, two counter/timers, a full-duplex serial port, and two parallel ports. The processor operates at 11 MHz. This allows most instructions to execute in 1.1 microseconds.

The 8051 has separate addresses for program storage and RAM. \overline{PSEN} selects program storage. The terminal uses ROM for program storage.

The microcontroller communicates over an 8-bit data bus which has eight lower order address bits multiplexed during bus cycles. The lower address bits are latched into an 8-bit latch by the ALE signal. The upper eight address bits have a dedicated output port on the 8051.

Table 6-2 is a list of 8051 port assignments.

Table 6-2 8051 Port Assignments

Port	Assignment
P0.0-P0.7	Data bus and lower byte of address bus.
P1.0	80/132 column enable. Output from the 8051 to enable the clock rate that selects 80- or 132-column mode. 0 enables the 26.580 MHz clock and 80-column mode. 1 enables the 39.710 MHz clock and 132-column mode.
P1.1	EEPROM serial data/address. Serial data interchange line to and from the EEPROM. Both address and data share this line. Addresses are serially shifted, a bit at a time, into the EEPROM. Data is then read back serially.

Table 6-2 8051 Port Assignments, Continued

Port	Assignment
P1.2	EEPROM clock. This state, combined with the state on P1.1, determines incoming data types: start/stop bits, acknowledgment, address, or actual data.
P1.3	/DSR AUX. Data Set Ready line on the AUX port.
P1.4	/DTR AUX. Data Terminal Ready line on the AUX port.
P1.5	Keyboard CMD. Command output to the keyboard.
P1.6	KBD data.
P1.7	MPS vertical size.
P2.0-P2.7	High byte of address bus.
P3.0	RXD AUX. Receive Data line on the AUX port.
P3.1	TXD AUX. Transmit Data line on the AUX port.
P3.2 (INT0)	2672 BREQ. Input from the 2672 indicating that display data transfers from RAM to the row buffers are about to occur.
P3.3 (INT1)	2661 INTR. Interrupt input from the 2681A. Indicates data in the receive buffer.
P3.4 (T0)	2672 INTR. Interrupt input indicates the start of vertical synchronization.
P3.5 (T1)	Baud rate clock.
P3.6	WR strobe. I/O write signal output by 8051.
P3.7	RD strobe. I/O read signal output by 8051.

Communication Interface

Both serial ports, the MODEM port and AUX port, are asynchronous. In setup, both the MODEM and AUX ports can be independently configured to connect to computers, modems, or printers.

MODEM Port--The 2661 UART controls the MODEM port. The MC1488 driver (U26) and the MC1489A receiver (U25) are both RS232 compatible. The 2661 (U3) converts parallel logic PCB data to bit-serial data, while adding stop, start, and parity bits. The serial format is transmitted at user-selected baud rate.

AUX port--The AUX port is controlled by the UART within 8051, pins 4, 5, 10, and 11. Pin 4 of the 8051 is reserved for data set ready signals, Pin 5 is reserved for data terminal ready signal. Pins 10 and 11 transmit and receive data. The MC1488 driver (U27) and the MC1489A receiver (U28) are both RS232 compatible. The 8051 itself converts parallel logic PCB data to bit-serial data, while adding stop, start, and parity bits. The serial format is transmitted at user-selected baud rate.

Display Memory

The display memory in the terminal is dual-ported between the CRT controller and the 8051. There are two 8Kx8 RAM chips installed for single-page operation. During the first scan line of each character row, the 2672 PVTC sends an interrupt on INTO of the 8051 nine microseconds before starting a DMA transfer from the display RAM. The 8051 cannot access the display RAM, the 2672, or the 2661 during DMA transfers. The 8051 does not stop during the DMA transfer, but cannot access other external devices.

Nonvolatile Memory

The terminal stores all configuration parameters in the nonvolatile EEPROM (U2). The memory operates from the +5 volt supply. Address and data information are clocked into the EEPROM through bidirectional SDA pin 5. Pin 6 is the clock synchronizing clock pin 5.

Keyboard Interface

Each key on the keyboard is tested for key depression by advancing the keyboard row/column counter to its address, then testing the line on the 8051. At least six microseconds elapse between outputting an address and testing the key return. Debouncing and multiple key depressions are handled by the 8051.

Video Control

Video control consists of the video clock circuitry, programmable video timing controller, attribute control, character generator, and video shift register.

Video Clock Circuitry--Either a 26.580 MHz (X1, for 80-column mode) or a 39.710 MHz oscillator (X2, for 132-column mode) generates timing for the dot clock and character clock. Both are TTL versions of Pierce oscillators.

Both oscillators are enabled by pin 1 from the 8051. Pin 1 is the 80/132 column switch line. Once enabled, the 39.710 MHz oscillator generates a 132-column display. The 26.580 MHz oscillator generates an 80-column display.

The output from either oscillator is buffered by the 74S00. The dot clock from the dividers goes to the pin 1 of the gate array.

Within the gate array, the character clock generator includes a counter and combinational logic which divides the dot clock by 10 in 80-column mode for a CCLK rate of 2.658 MHz and by 9 for a CCLK rate of 4.412 MHz in 132-column mode.

Programmable Video Controller--The 2672 programmable video timing controller (PVTC) (U9) provides all the timing and control signals for displaying characters on the CRT. The 8051 initializes the 2672 with the display parameters when a user turns the terminal on. Before each displayable character row, the 8051 gives the 2672 the beginning character address for that row. The 2672 fetches characters from the display RAM during the first scan line of each displayable character row. During the following 15 scan lines the characters are retrieved from the row buffer.

The 2672 warns the 8051 of an impending DMA transfer by asserting BREQ nine microseconds before the DMA transfer begins. After nine microseconds, the 2672 asserts memory bus control (MBC) which ports the display RAM into the row buffer RAM.

Attribute Control--Attribute control determines the way the CRT displays characters. There are six attributes: normal, dim, blank, reverse, blink, and underline. There are two attribute modes: hidden and nonhidden.

Attribute control data in the hidden attribute mode doesn't occupy any space in the video RAM (U7) that stores character data. Instead, the attribute data or information is stored in separate RAM (U8) reserved for attribute data.

Attribute control data in the nonhidden attribute mode does occupy a space in the video RAM that stores character data. The code signaling any attribute to be displayed occupies the character space on the screen before the text that will be displayed in that attribute.

Font RAM--Each character cell is 10 x 16 (80 column) or 9 x 16 (132 column) with a character matrix of 7 x 12 dots (with three dot decenders.) The font RAM (U19) is a 6264 (8Kx8) RAM that stores displayable and nondisplayable characters and symbols.

Video Shift Register--The video shift register (gate array) sends the serial bit stream to the video input of the monitor circuitry. The shift register loads parallel character data from the character generator RAM at the CCLK rate, and shifts the data out serially at the dot clock rate to the video drive circuitry within the monitor circuitry.

RASTER SCAN TERMINOLOGY

The terminal has a 14-inch cathode ray tube (CRT) display. Because the terminal has a video output, most of its circuitry provides the appropriate inputs to the CRT display (i.e., clock and video information).

An electron beam sweeps the face of the CRT. The electron beam begins in the upper left-hand corner of the display and sweeps from left to right. One sweep of the beam is called a "scan line." When the beam returns from the right side of the screen to the left side, beginning the next scan line, it must be disabled (turned off). This prevents a streak from appearing on the face of the CRT. Disabling the beam is called "horizontal blanking." At the end of 416 scan lines, the electron beam arrives at the lower right-hand corner of the display. In order to return to the upper left-hand corner, the beam must be disabled again so a vertical streak doesn't appear on the face of the CRT. Disabling the beam at this time is called "vertical blanking." The amount of time it takes the beam to move from the upper left-hand corner of the display and return is a "field." The terminal uses a 60 Hz field rate in either 60 Hz or 50 Hz AC input.

7 SCHEMATICS AND PCB ASSEMBLY DRAWINGS

Schematic	Part	Figure	Page
Keyboard PCB, WY-60 ASCII	960112-01	7-1	7-3
Keyboard PCB, AT-Style	960088-01	7-2	7-5
Keyboard PCB, 316X-Style	960113-01	7-3	7-7
Terminal PCB Logic, (1 of 3)	960100-01	7-4	7-9
Terminal PCB Logic, (2 of 3)	960100-01	7-4	7-11
Terminal PCB Monitor/Power Supply, (3 of 3)	960100-01	7-4	7-13
PCB Assembly Drawing	Part	Figure	Page
Keyboard PCB, WY-60 ASCII	990112-01	7-5	7-15
Keyboard PCB, AT-Style	990088-01	7-6	7-16
Keyboard PCB, 316X-Style	990113-01	7-7	7-17
Terminal PCB	990100-01	7-10	7-18

Figure 7-1 WY-60 ASCII Keyboard PCB Schematic

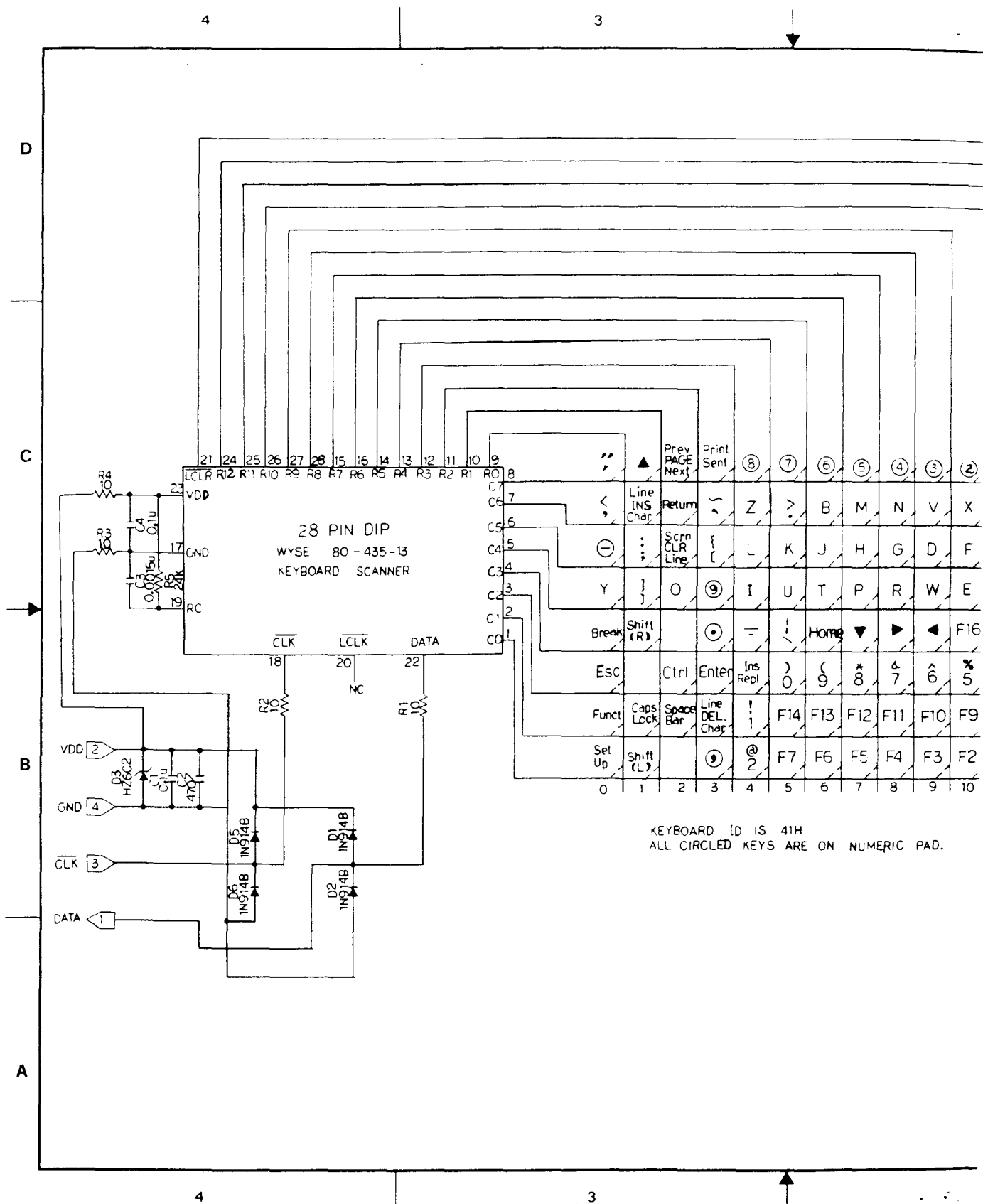

Schematic

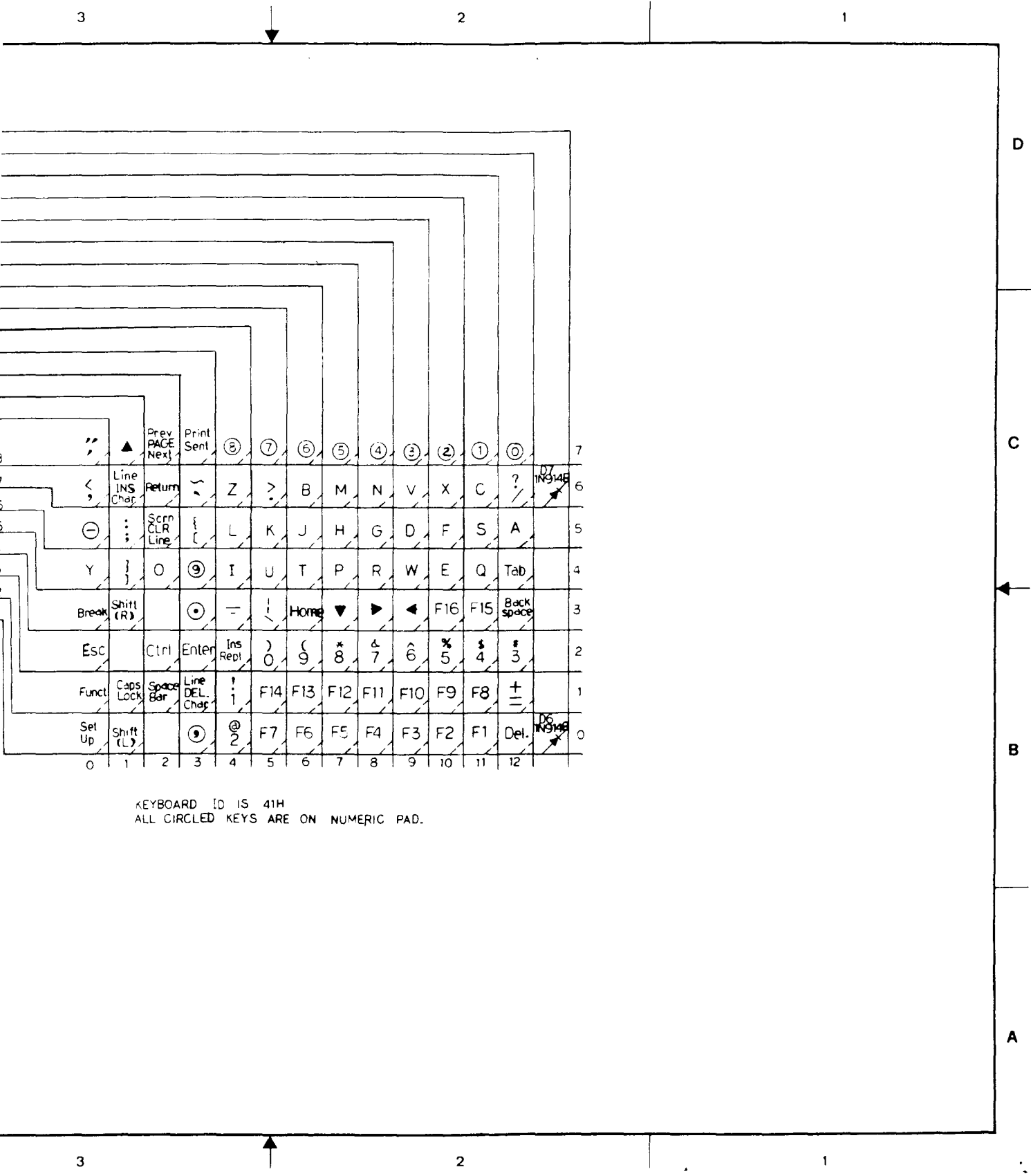

KEYBOARD ID IS 41H
 ALL CIRCLED KEYS ARE ON NUMERIC PAD.

Figure 7-2 AT-Style Keyboard PCB Schematic

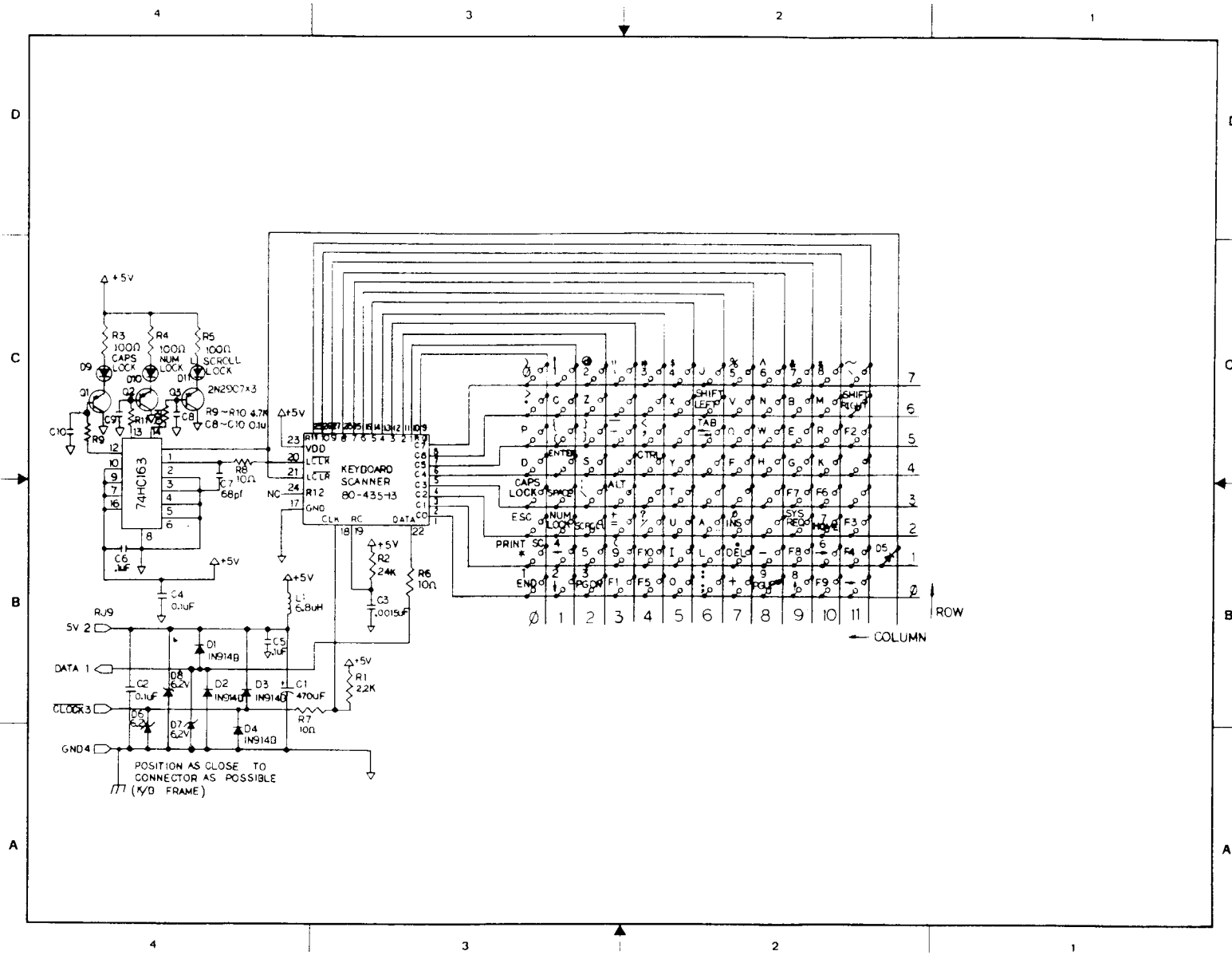
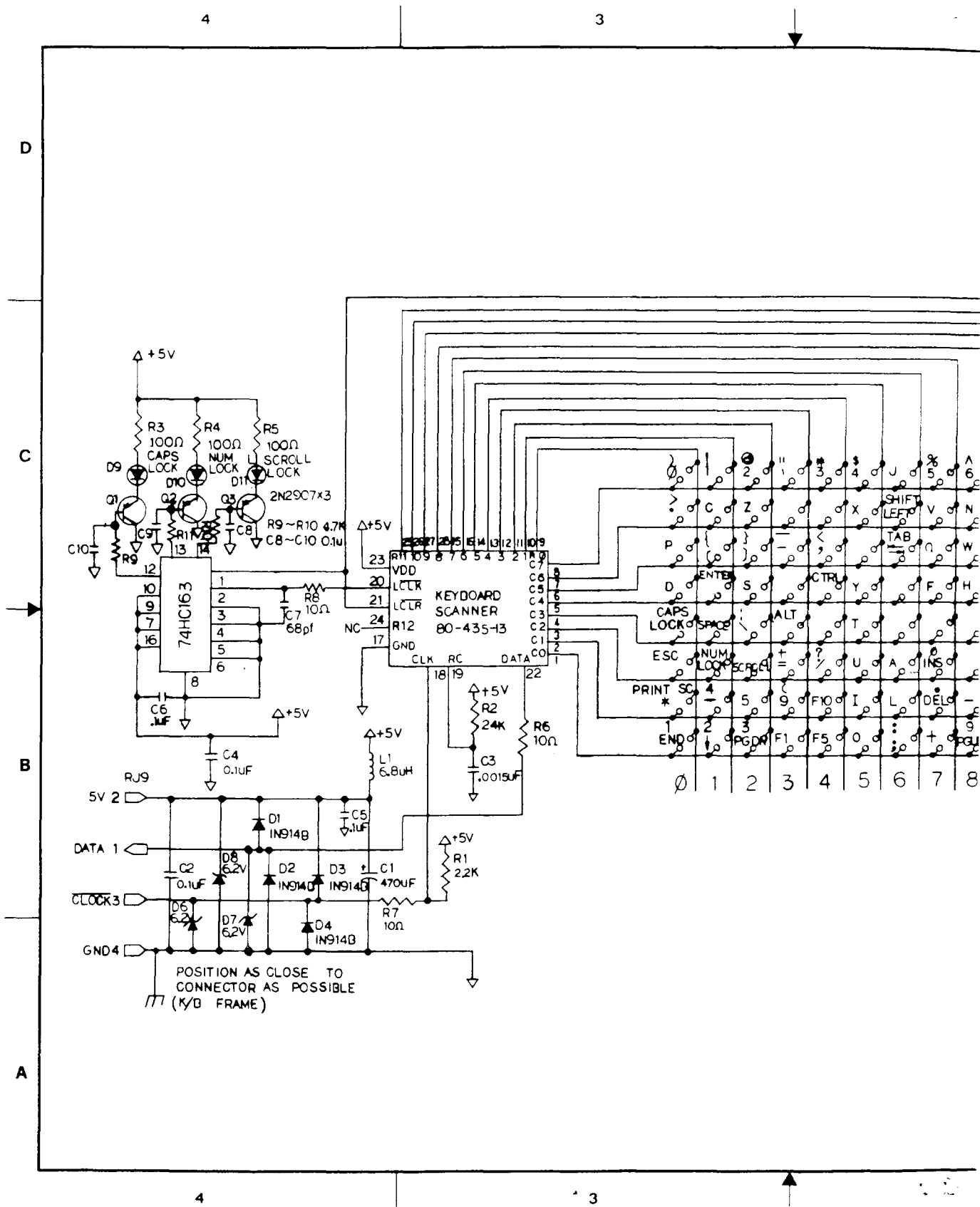

Figure 7-2 AT-Style Keyboard PCB Schematic



matic

3

2

1

D

C

B

A

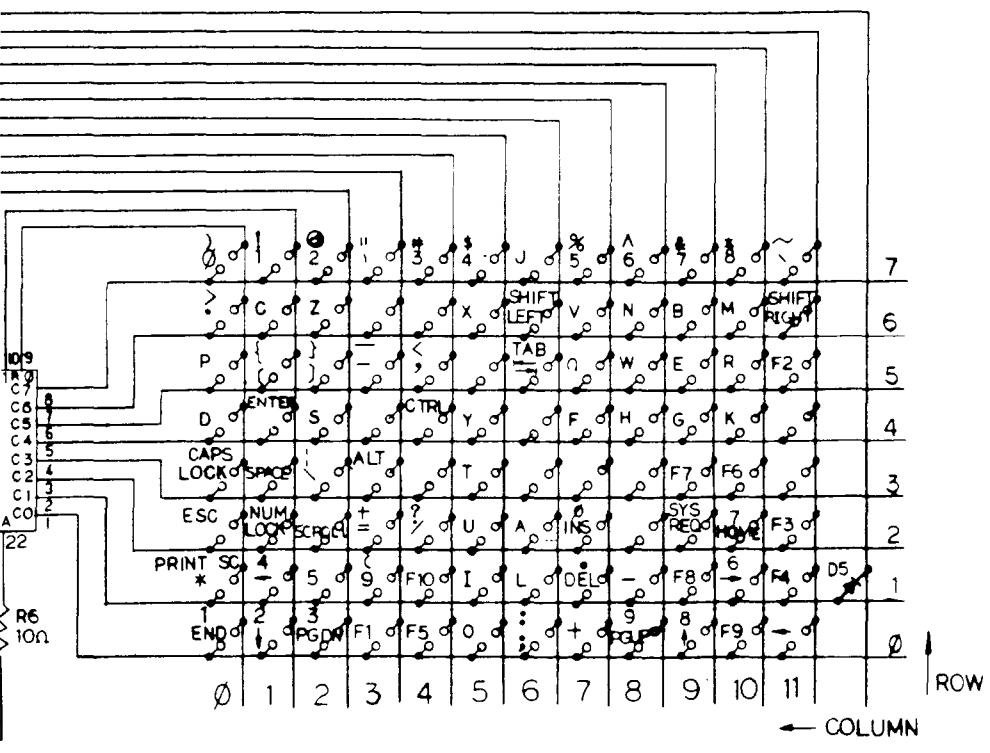

IO9
 IN9
 C7
 C6
 C5
 C4
 C3
 C2
 C1
 A COL
 22
 R6
 10n

ROW

COLUMN

For Service Manuals
MAURITRON SERVICES
 8 Cherry Tree Road, Chinnor
 Oxfordshire, OX9 4QY.
 Tel (01844) 351694
 Fax (01844) 352554
 email:- mauritron@dial.pipex.com

3

2

1

Figure 7-3 316X-Style Keyboard PCB Schematic

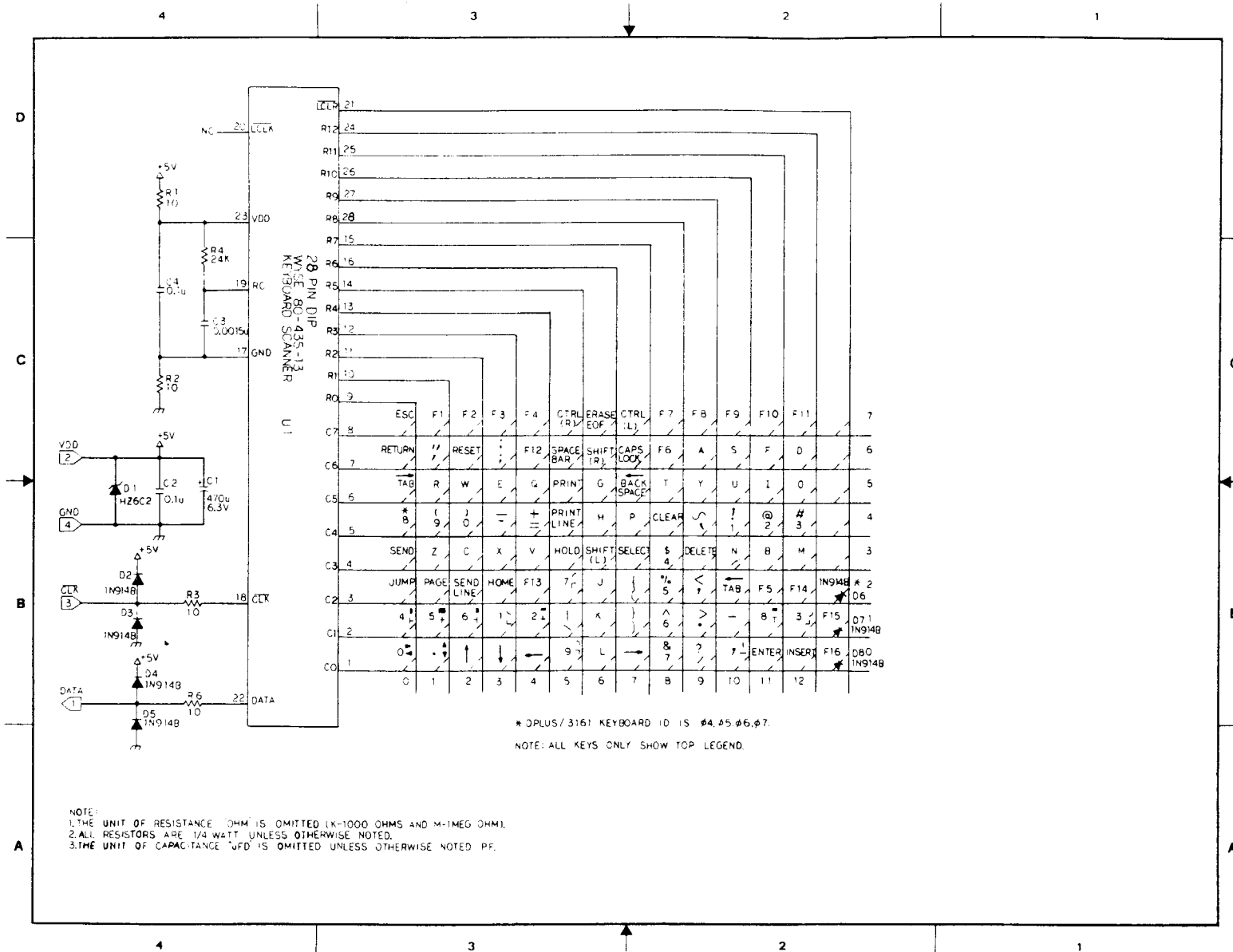
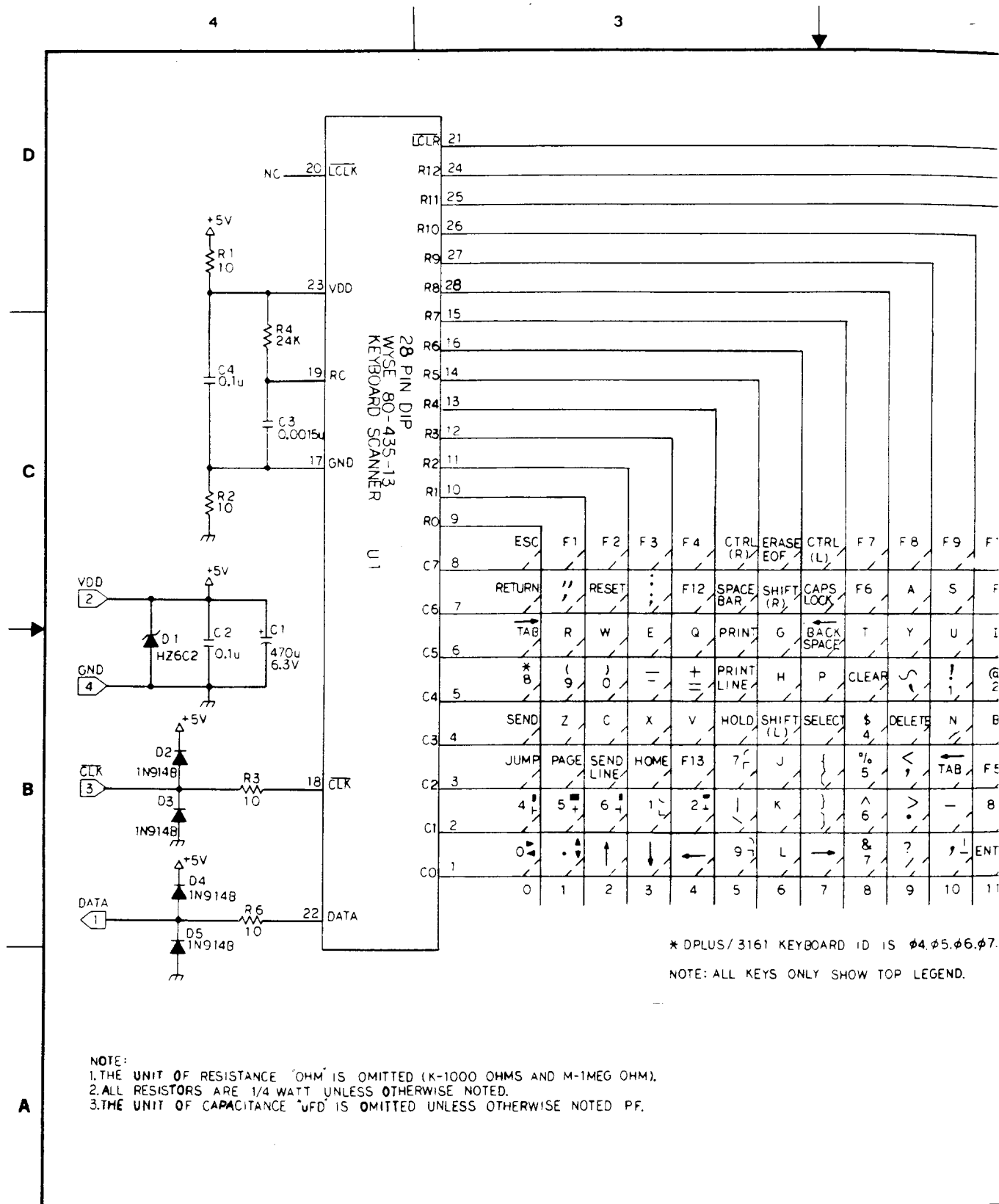
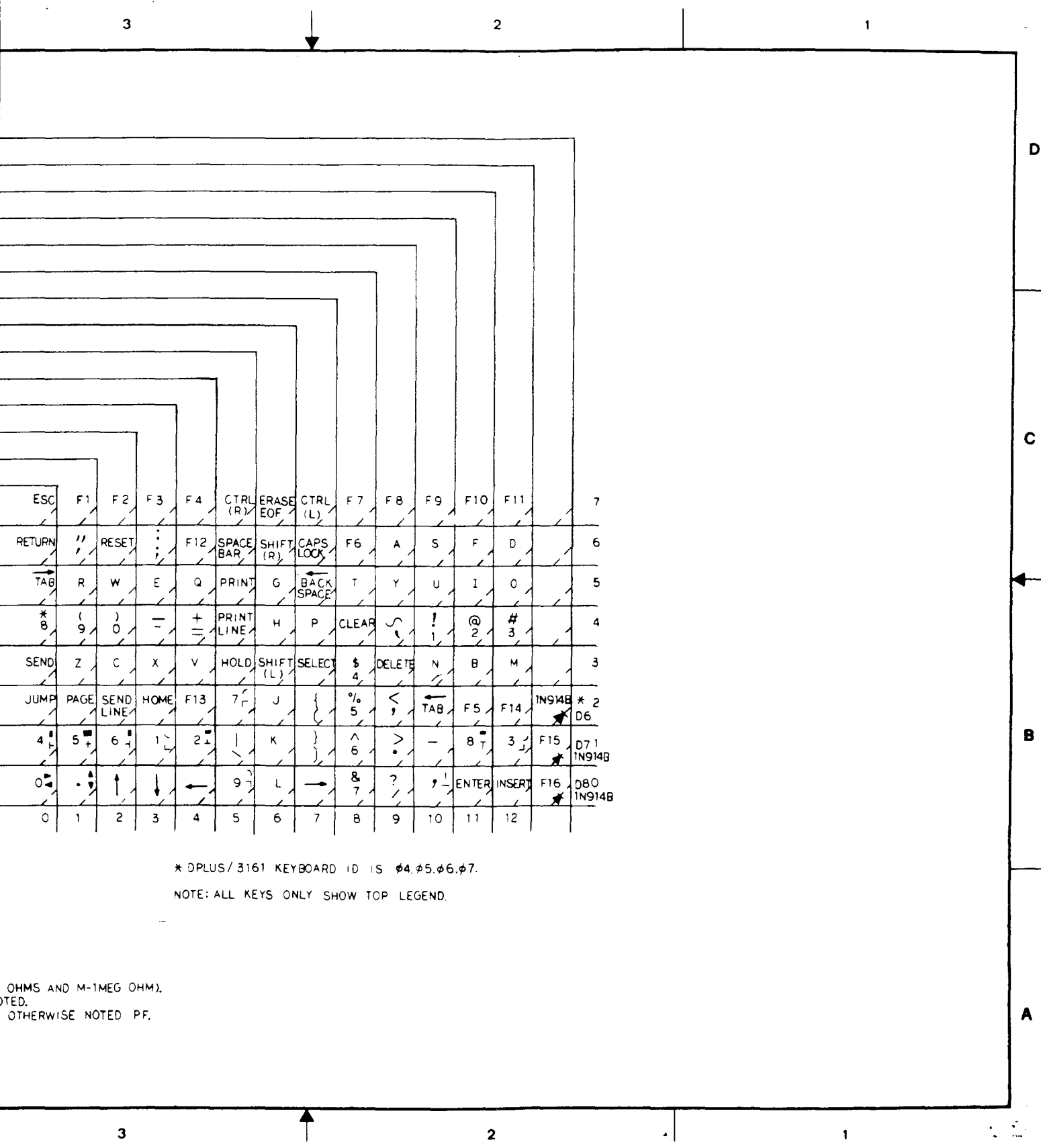

Figure 7-3 316X-Style Keyboard PCB Schematic



KB Schematic



* DPLUS/3161 KEYBOARD ID IS 04,05,06,07.
 NOTE: ALL KEYS ONLY SHOW TOP LEGEND.

0 OHMS AND M-1MEG OHM).
 OTED.
 S OTHERWISE NOTED PF.

Figure 7-4 Terminal PCB Schematic (Logic), page 1 of 3

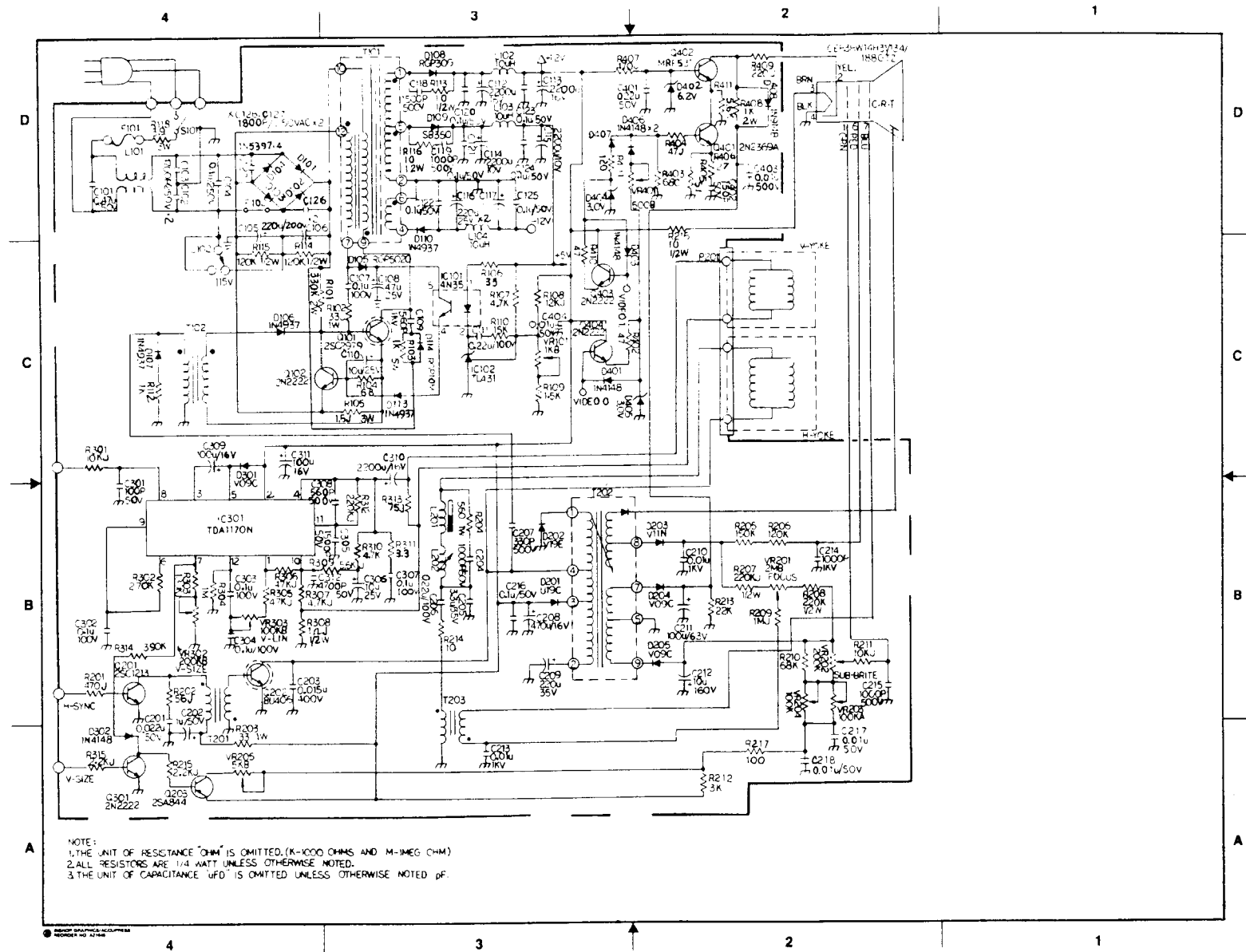
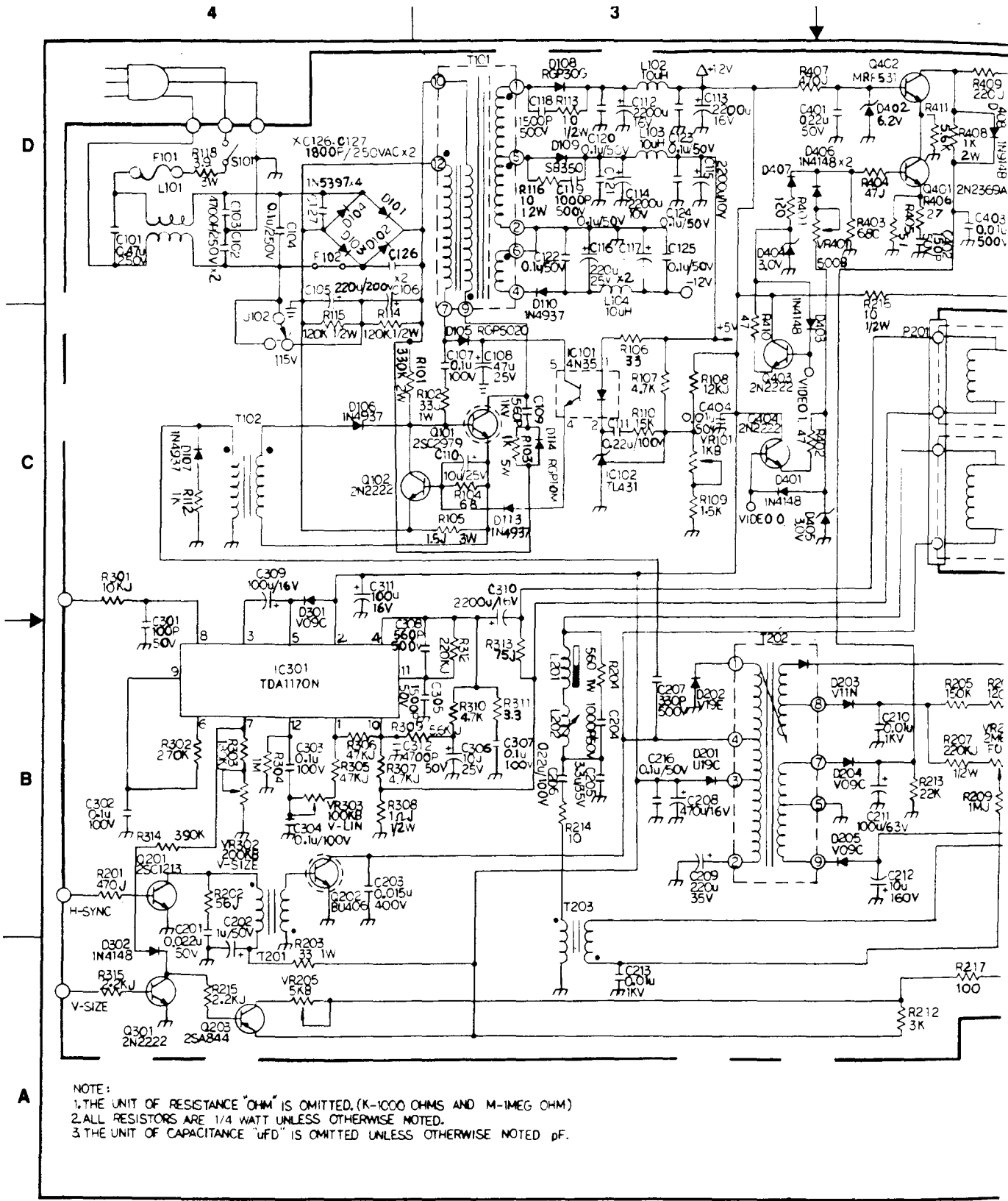

Figure 7-4 Terminal PCB Schematic (Logic), page 1 of 3



NOTE:
 1. THE UNIT OF RESISTANCE "OHM" IS OMITTED. (K-1000 OHMS AND M-1MEG OHM)
 2. ALL RESISTORS ARE 1/4 WATT UNLESS OTHERWISE NOTED.
 3. THE UNIT OF CAPACITANCE "uFD" IS OMITTED UNLESS OTHERWISE NOTED pF.

BRIDGES GRAPHICS/ACCOMPRESS
 REORDER NO. A2146

3

2

1

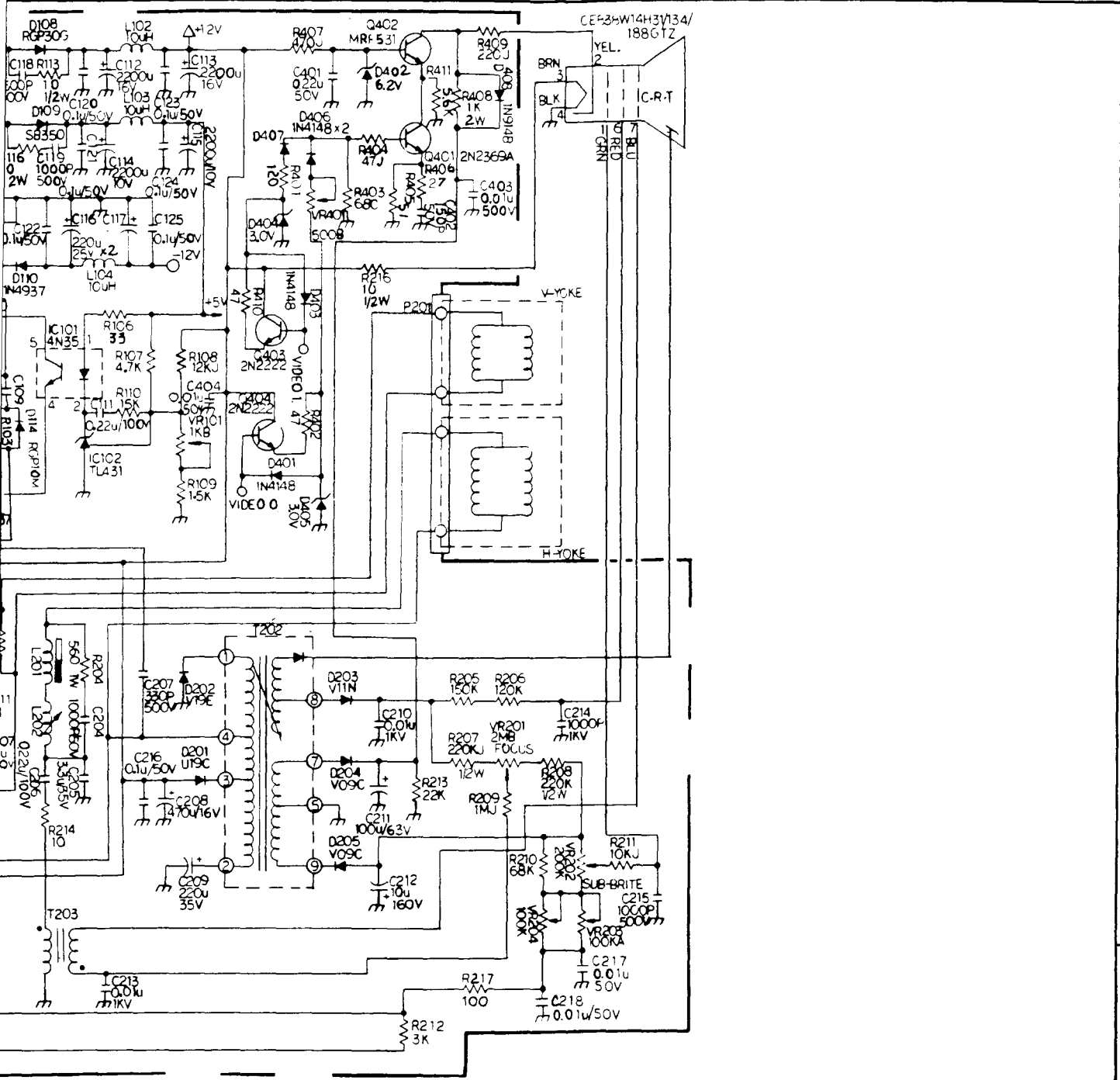

D

C

B

A

3

2

1

REG OHM)
ATED p.F.

Figure 7-4 Terminal PCB Schematic (Logic), page 2 of 3

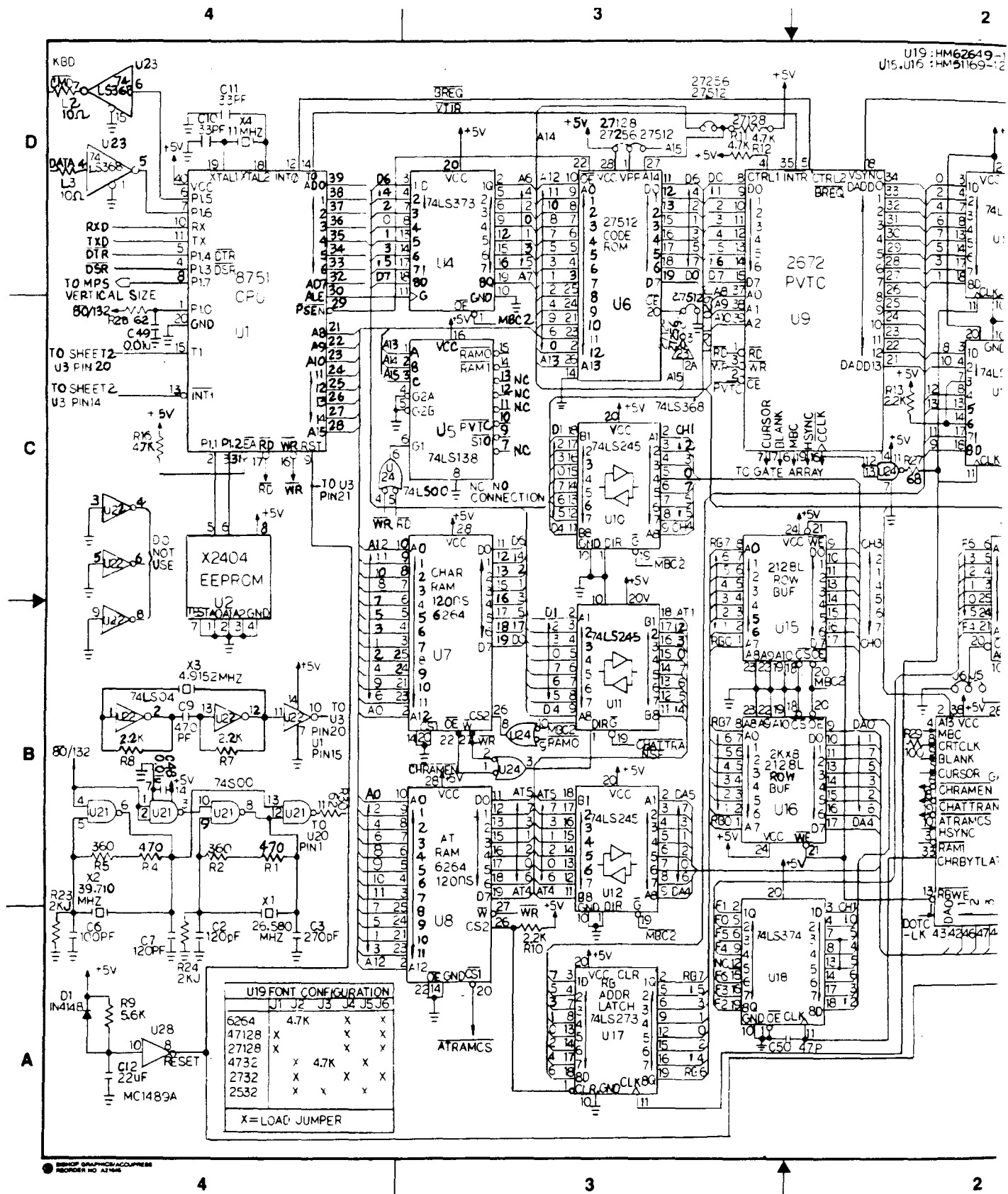

Figure 7-4 Terminal PCB Schematic (Monitor/Power Supply),
page 3 of 3

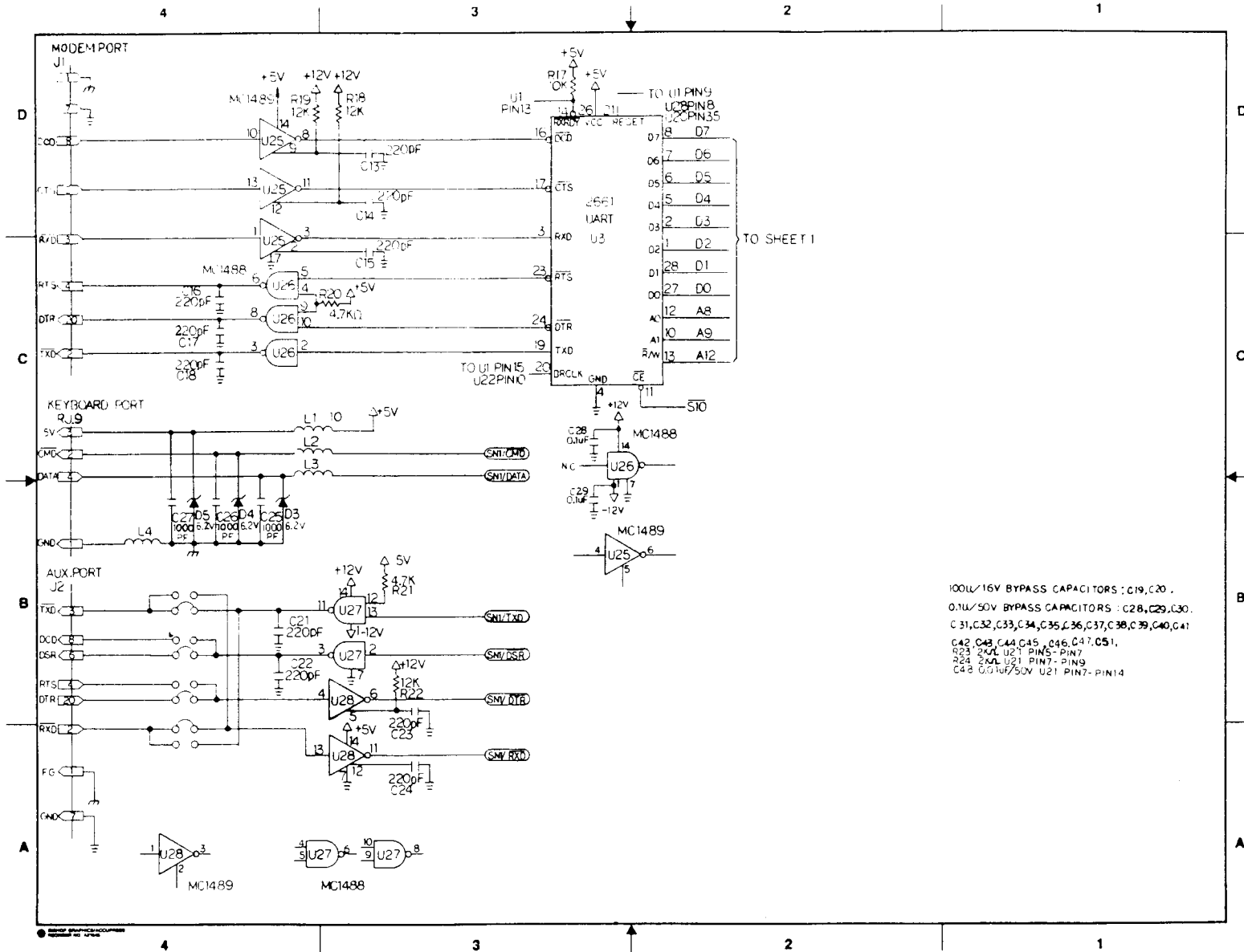
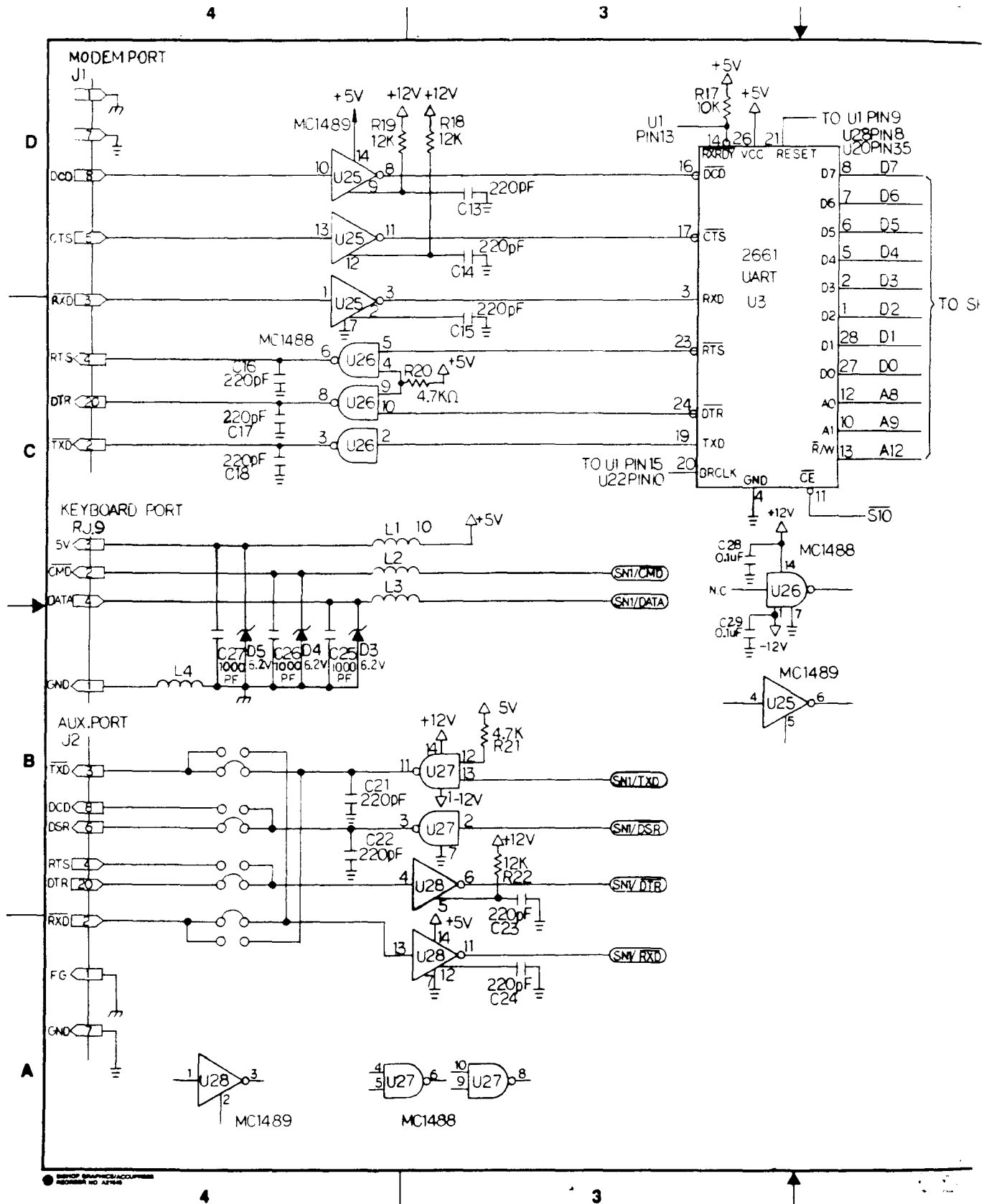
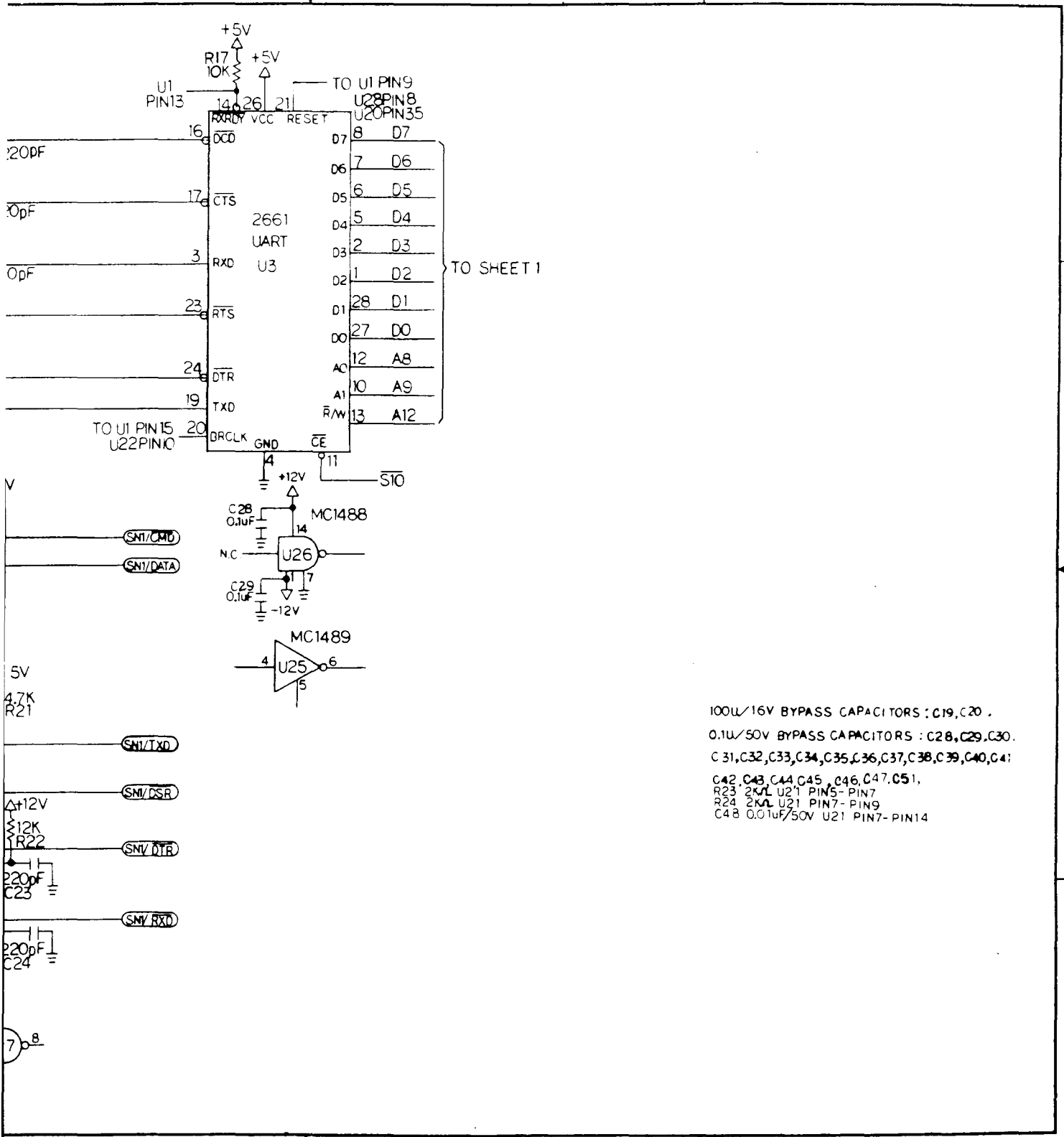

Figure 7-4 Terminal PCB Schematic (Monitor/Power Supply), page 3 of 3



(Monitor/Power Supply),

3 2 1



TO SHEET 1

- 100LL/16V BYPASS CAPACITORS : C19, C20 .
- 0.1u/50V BYPASS CAPACITORS : C28, C29, C30.
- C 31, C32, C33, C34, C35, C36, C37, C38, C39, C40, C41
- C42, C43, C44, C45, C46, C47, C51,
- R23 2KΩ U21 PIN5- PIN7
- R24 2KΩ U21 PIN7- PIN9
- C48 0.01uF/50V U21 PIN7- PIN14

D
C
B
A

3 2 1

Figure 7-5 WY-60 ASCII Keyboard PCB Assembly Drawing

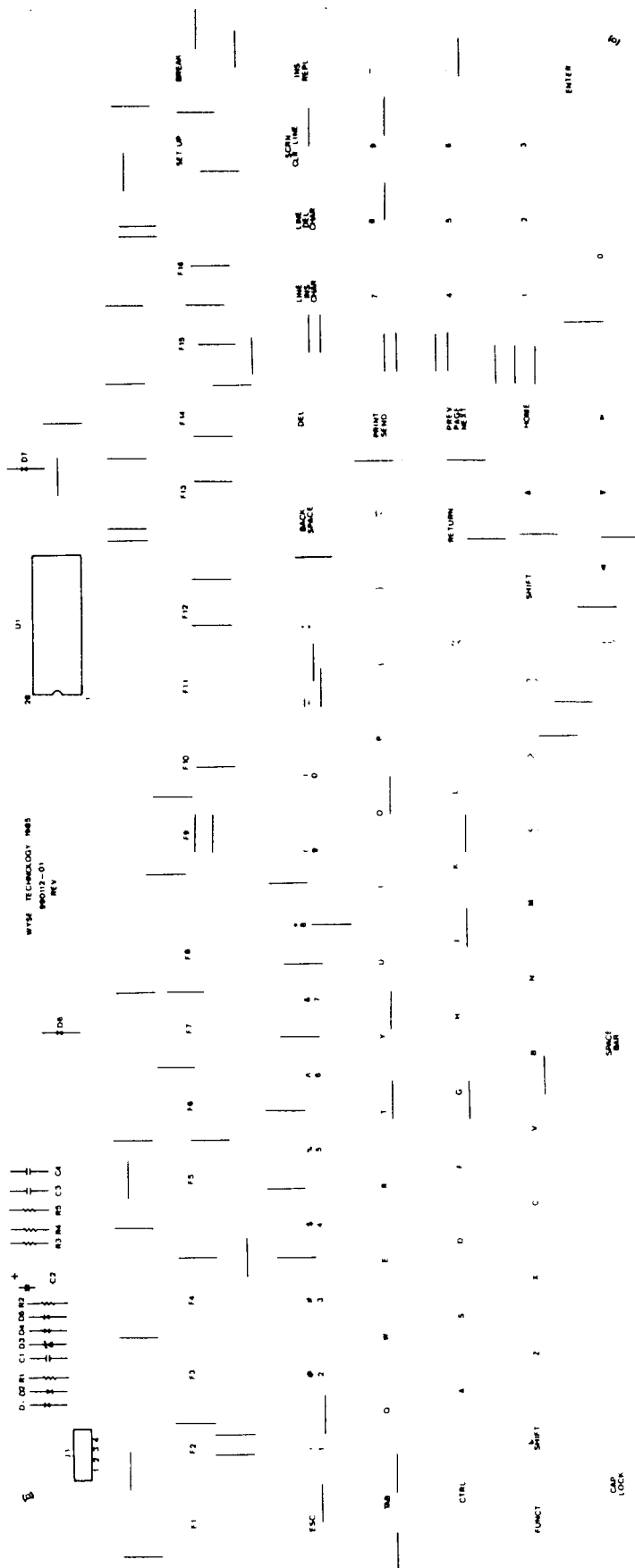

Figure 7-6 AT-Style Keyboard PCB Assembly Drawing

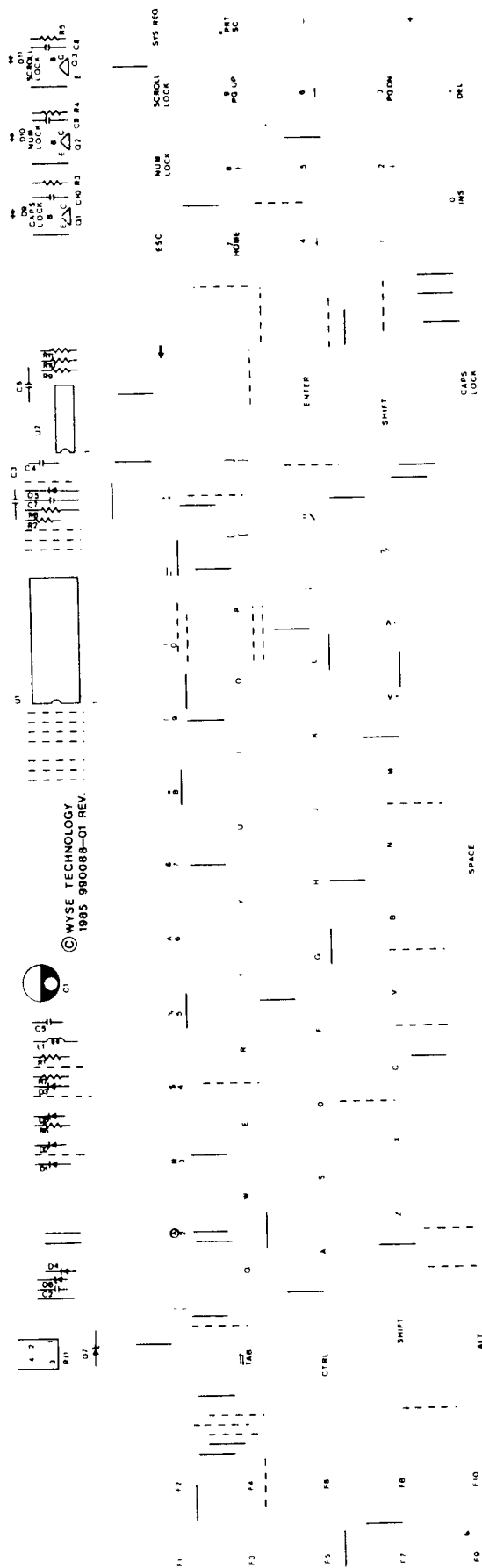

Figure 7-7 316X-Style Keyboard PCB Assembly Drawing

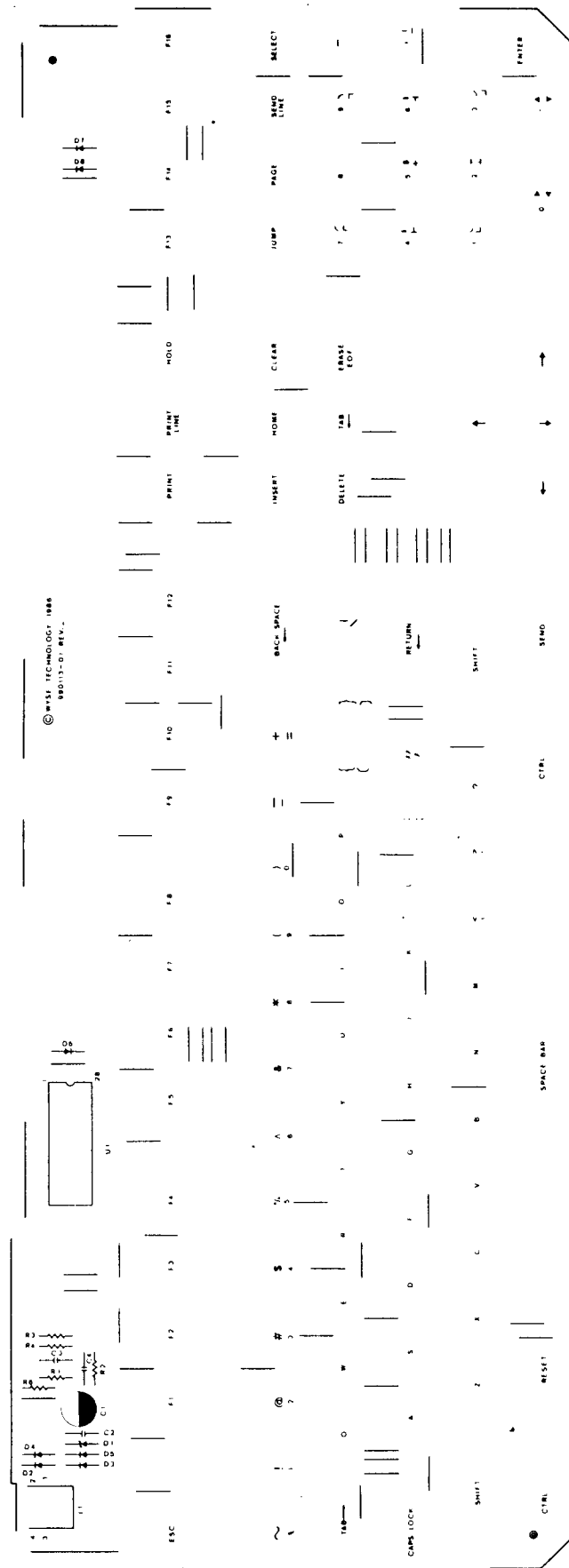
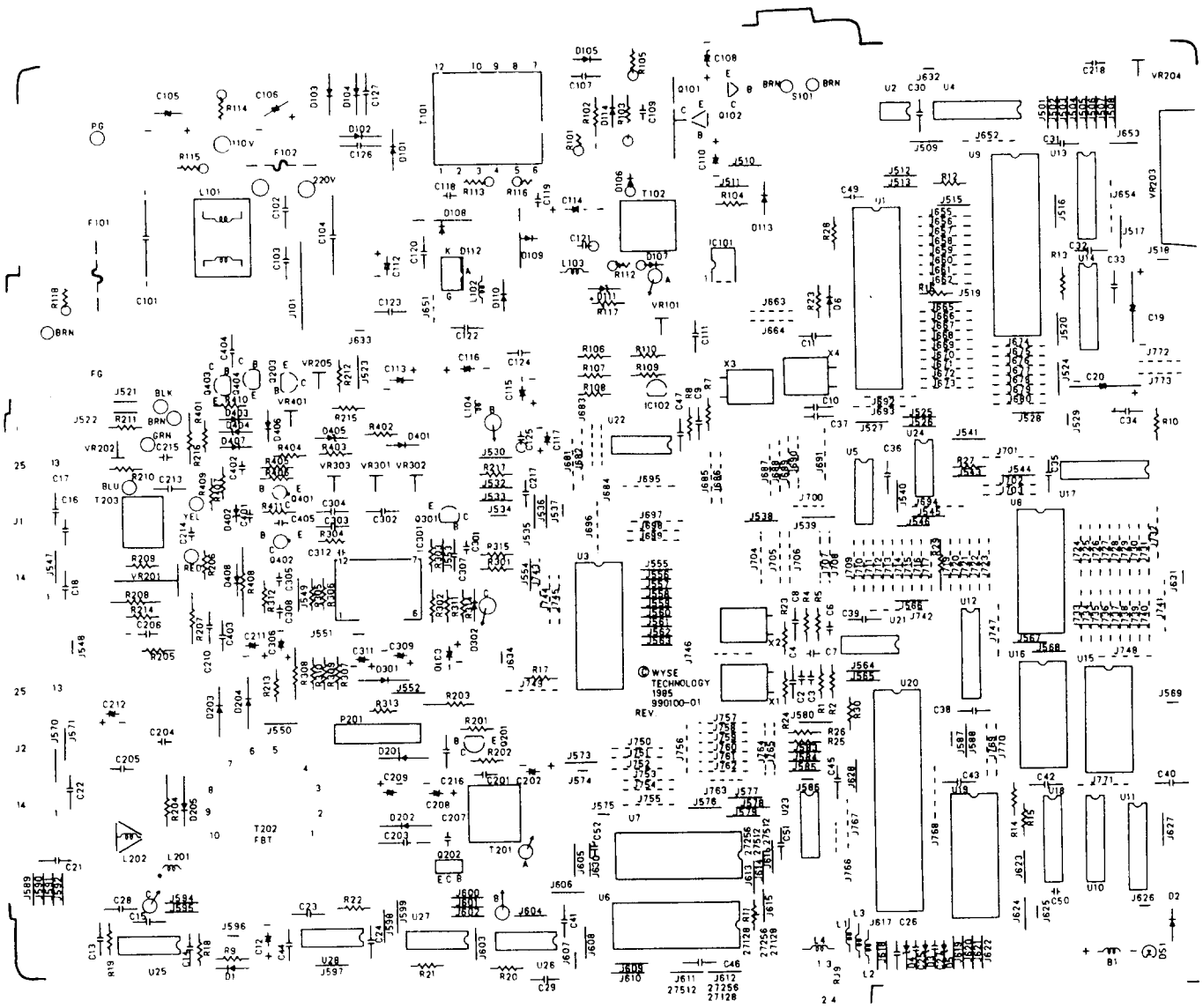

Figure 7-8 Terminal PCB Logic Assembly Drawing



APPENDIX A SPECIFICATIONS

Power Requirements

Domestic	
Line voltage	98 to 132 VAC
Line frequency	57 to 63 Hz
Power consumption	45 watts
Fuse	125V, 2.0 ampere fast blow
International	
Line voltage	196 to 264 VAC
Line frequency	47 to 53 Hz
Power consumption	45 watts
Fuse	250V 1.60 ampere slow blow

Operating Requirments

Ambient air temperature	+10 to +40 degrees Centigrade
Nonoperating air temperature	-40 to +60 degrees Centigrade
Operating altitude	10,000 feet, ASL
Nonoperating altitude	40,000 feet, ASL
Environmental humidity	20 to 80%, noncondensing

Scan Frequency

Horizontal	26.580 kHz
Vertical	60.000 Hz

Display Time

Horizontal	30.08 us
Vertical	15.65 ms

Retrace Time

Horizontal	5.40 us (maximum)
Vertical	.40 ms (maximum)

Resolution

Horizontal	
80 columns	800 dots
132 columns	1188 dots
Vertical	416 lines

Display Format

Horizontal	80 or 132 columns
Vertical	26 or 44 rows

Character Cells and Matrices

80 columns, 26 lines	
Character cell	10 x 16
Character matrix	7 x 12
132 columns, 26 lines	
Character cell	9 x 16
Character matrix	7 x 12
80 columns, 44 lines	
Character cell	10 x 9
Character matrix	5 x 7
80 columns, 132 lines	
Character cell	9 x 9
Character matrix	5 x 7

Memory

Seven pages	26 lines x 80 columns
Four pages	26 lines x 132 columns
Three pages	26 lines x 80 columns, hidden attributes mode
Two pages	26 lines x 132 columns, hidden attributes mode 44 lines x 80 columns 44 lines x 132 columns
One page	44 lines x 80 columns, hidden attributes mode 44 lines x 132 columns, hidden attributes mode

Display Size

Horizontal	237 mm, <u>+2</u> mm
Vertical	172 mm, <u>+2</u> mm

Display Intensity, Nominal

P31 Green	
Full bright	50 fL, <u>+8</u> fL
Normal	33 fL, <u>+8</u> fL
Dim	17 fL, <u>+8</u> fL
P134 Amber	
Full bright	30 fL, <u>+4</u> fL
Normal	20 fL, <u>+4</u> fL
Dim	13 fL, <u>+4</u> fL
P188 White	
Full bright	35 fL, <u>+5</u> fL
Normal	24 fL, <u>+5</u> fL
Dim	15 fL, <u>+5</u> fL

Linearity

Horizontal	12%
Vertical	12%

Centering

Margin tolerance	+4.00 mm
Pincushion and tilt	+2.00 mm

Measurement Direction

CRT neck pointing north

Warmup Time

30 minutes

FCC

Meets FCC rules and regulations, Part 15, Subpart J, Class A

UL

Meets US specification number 478 for EDP units and systems

CSA

Meets CSA specification C22.2, number 154

VDE/IEC

Designed to meet IEC Standard 380/VDE Standard 806, and VFG 1046/1984 VDE Level B specifications. Pending approval.
(International Version only)

Dimensions

Terminal	12.5"H x 12.5"W x 13"D (32cm x 32cm x 33.5cm)
Screen	14" diagonal, flat (35cm)
Keyboard	
WY-60 ASCII	2.25"H x 17.25"W x 7.6"D (5.77cm x 44.23cm x 19.48cm)
316X Style	2.25"H x 19.00"W x 7.0"D (5.77cm x 48.72cm x 17.95cm)
AT Style	2.25"H x 17.75"W x 5.5"D (5.77cm x 45.51cm x 14.1cm)

Shipping Weight

20 lbs

Movement

Tilt and swivel

Phosphor

P31 green
P134 amber
P188 white

Character Attributes

Normal, dim, blink, blank,
underline, reverse,
underscore, and combinations:
hidden or nonhidden

Line Attributes

Double wide, double high and
combinations, dim, reverse

Cursor Attributes

Block, underline, with or
without blinking

APPENDIX B CONNECTOR PIN ASSIGNMENTS

Figure B-1 Pin Numbers (MODEM and AUX Ports)

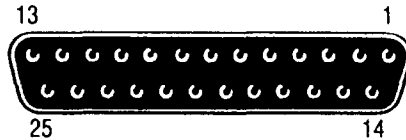

Table B-1 MODEM Port Connector Pin Assignments (DTE)

Pin	Signal	Mnemonic	Direction
1	Shield Ground	PGND	
2*	Transmit Data	TXD	Out
3*	Receive Data	RXD	In
4	Request to Send	RTS	Out
5+	Clear to Send	CTS	In
7*	Signal Ground	SGND	
8+	Data Carrier Detect	DCD	In
20*	Data Terminal Ready	DTR	Out

* Typical requirement.
 + Modem protocol. We recommend that users leave it disconnected. If pin 5 is low, the terminal won't transmit any data. If pin 8 is low, the terminal won't receive any data.

Table B-2 Typical Modem Pin Assignments

Terminal (DTE)	Hayes Smartmodem 1200 (DCE)
1	1
2	2
3	3
7	7
20	20

We recommend that pins 6 and 8 be disconnected--they are modem protocols that can lock up the terminal.

Note--Hayes Smartmodem 1200 front panel switch settings are DUDUDDUD.

Table B-3 AUX Port Connector Pin Assignments (DCE)

Pin	Signal	Mnemonic	Direction
1	Shield Ground	PGND	
2*	Transmit Data	TXD	In
3*	Receive Data	RXD	Out
6	Data Set Ready	DSR	Out
7*	Signal Ground	SGND	
20*	Data Terminal Ready	DTR	In

* Typical configuration

APPENDIX C TEST CONNECTORS

This appendix describes connections, signals connected, and the connector hood types needed for making the test connectors referenced in Chapters 3 and 4. If you prefer, you can order sets of them. See Chapter 5.

MODEM Port

Use a male DB-25 pin connector. Connect these pins (signals):

Pin 2 to Pin 3	(TXD to RXD)
Pin 4 to Pin 5	(RTS to CTS)
Pin 20 to Pin 8	(DTR to DCD)

AUX Port

Use a male DB-25 pin connector. Connect these pins (signals):

Pin 2 to Pin 3	(TXD to RXD)
Pin 6 to Pin 20	(DSR to DTR)

Back-to-Back Test Connectors

Use two male DB-25 pin connectors. Connect these pins (signals):

MODEM Pin 2 to AUX Pin 2	(TXD to TXD)
MODEM Pin 3 to AUX Pin 3	(RXD to RXD)

APPENDIX D DISPLAY INSPECTION WITH THE RETICLE

The video inspection reticle, a sheet of milled plastic with markings, helps you measure the 14-inch monochrome display to determine whether or not the display is within specification. Figure D-1 shows the reticle and its markings.

Figure D-1 Video Inspection Reticle

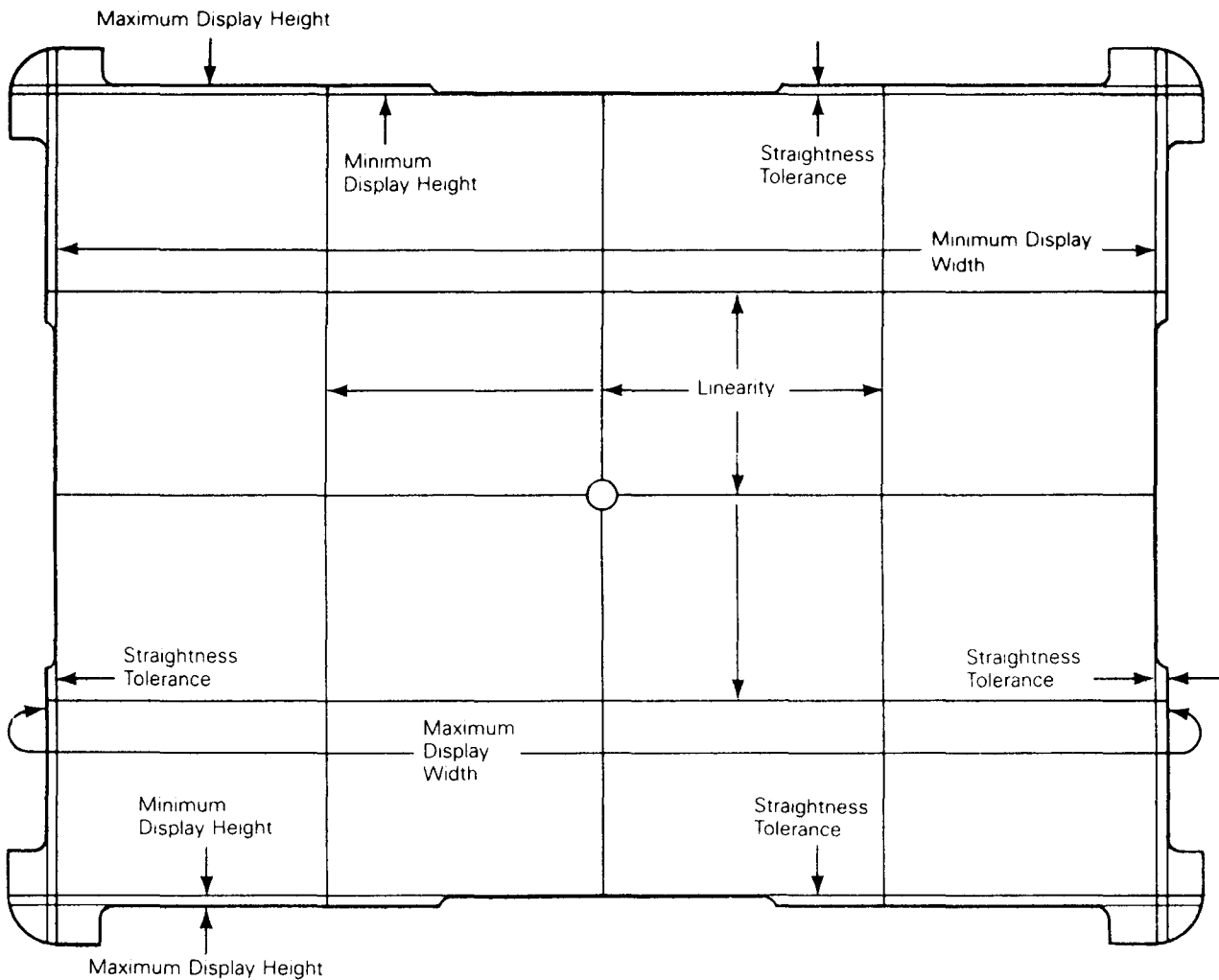

DEFINITIONS

Before checking the display, make sure you understand the following terms:

Bezel	The front-piece of the display case that frames the face of the CRT.
Display	The portion of the screen where the video display alignment pattern appears.
Linearity	A comparison of character height and width ranges in the display. You can check both vertical and horizontal linearity by comparing character height and width within the display. True linearity results in characters that are the same height and width range everywhere. See Appendix A for linearity tolerances.
Pincushion and Barrel Distortion	Distortion that results if deflection is not uniform at the raster edges when compared with the center of the display. Scan lines bowed inward are called "pincushion distortion". Scan lines bowed outward are called "barrel distortion".
Video Display Alignment Pattern	A test pattern to measure display alignment.

BEFORE YOU START

Before you check the alignment, do the following:

1. Turn on the terminal at least 30 minutes before you check the display. This warm-up period settles the display and gives you an accurate test pattern to measure.
2. Generate the terminal test pattern (see Chapter 4).
3. Point the neck of the CRT toward magnetic north to minimize the effects of the earth's magnetic field.
4. Have the video display reticle on hand to inspect the display.

CHECKING THE DISPLAY WITH THE RETICLE

Checking Width

To check the display's width, follow these steps:

1. Rest the reticle along the lower horizontal edge of the bezel.
2. Check the left vertical edge, then the right vertical edge, of the alignment pattern by moving the reticle along the edge of the bezel. Both edges should fall between the minimum and maximum display width bands on the reticle (see Figure D-2).
3. If either edge falls outside the bands, adjust the display (see the alignment instructions in Chapter 4).

Figure D-2 Checking Width and Height

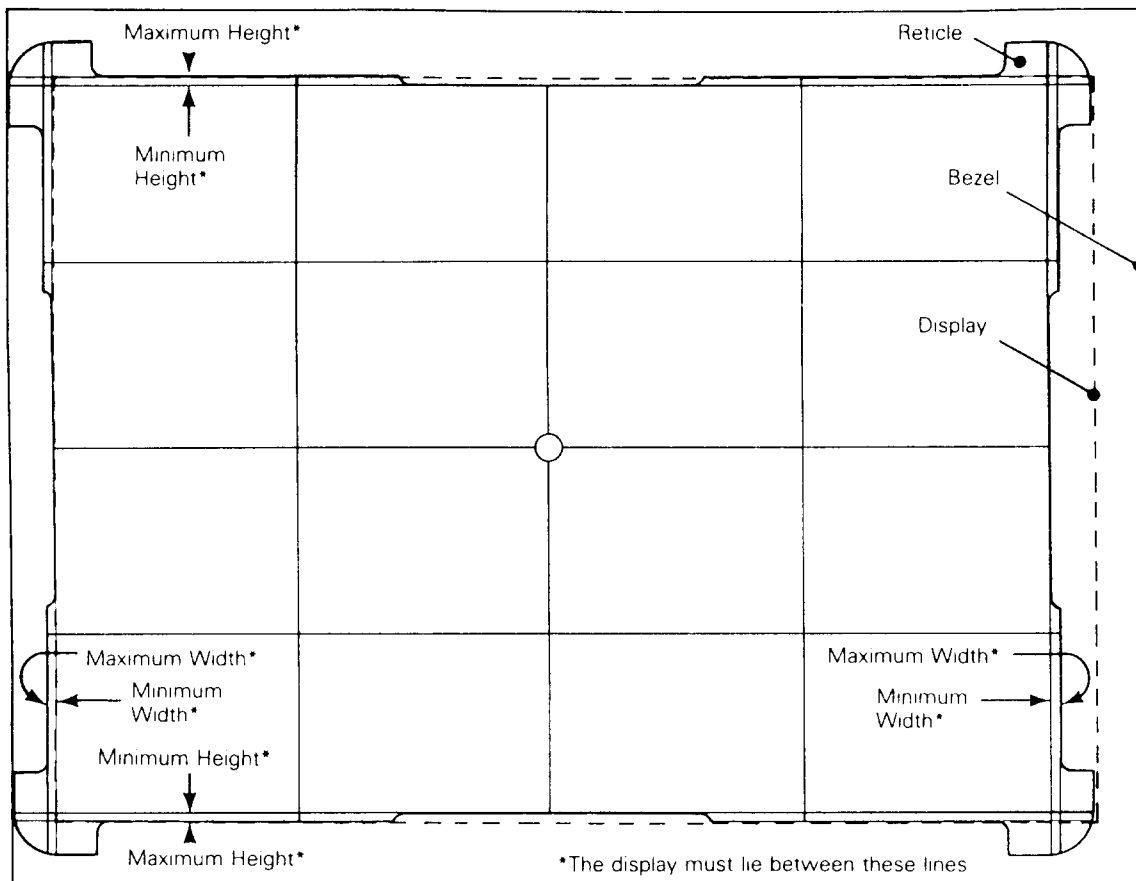

Checking Height

To check the display height, follow these steps:

1. Rest the reticle on the left vertical edge of the bezel.
2. Move the reticle up and down along the edge. Check the top edge, then the bottom edge, of the alignment pattern. Both edges should fall between the minimum and maximum display height bands on the reticle (see Figure D-2).
3. If one or the other edge falls outside the bands, adjust the display (see the alignment instructions in Chapter 4).

Checking Straightness and Pincushioning

To check straightness and pincushioning, follow these steps:

1. Move the reticle along a horizontal edge of the bezel. Check the right vertical edge, then the left vertical edge, against the straightness lines etched on the perimeter of the reticle (see Figure D-3).

Figure D-3 Checking Straightness, Pincushioning, Centering, and Vertical Linearity

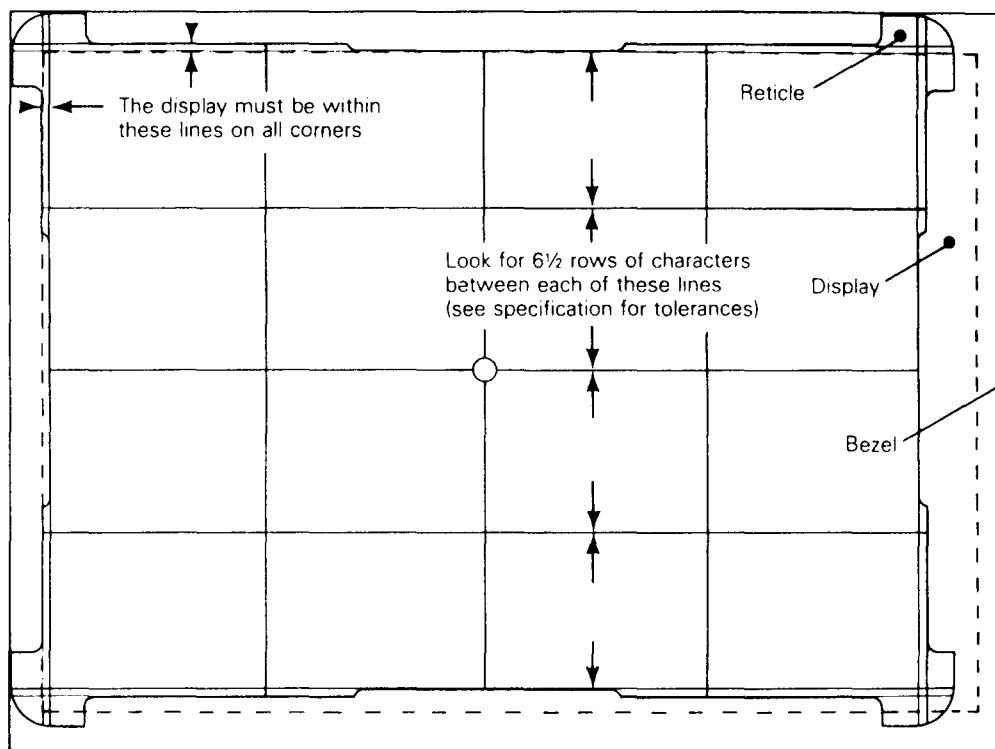

2. Move the reticle along a vertical edge of the bezel. Check the top edge, then the bottom edge, against the straightness lines etched on the perimeter of the reticle.
3. Position the upper right corner of the display between the etched markings on the upper right corner of the reticle. The display corner edge should fall within the scribed markings on the corner of the reticle.
4. Repeat the same procedure for the other corners of the display.
5. If an edge or corner doesn't fall within the markings, adjust the display (see Chapter 4).

Checking Centering

To check the centering follow these steps:

1. Hold the reticle over the center of the alignment pattern.
2. Move the reticle against the right edge of the bezel, then the left edge of the bezel. If the right and the left edges of the alignment pattern are inside the etched lines on the left and right sides of the reticle, the display is horizontally centered (see Figure D-3).
3. If the alignment pattern on the display isn't horizontally centered, adjust the display (see the instructions in Chapter 4).
4. Move the reticle against the top bezel edge, then the bottom bezel edge. If the top and the bottom edges of the alignment pattern are inside the etched lines on the top and bottom sides of the reticle, the display is vertically centered.
5. If the alignment pattern on the display isn't vertically centered, adjust the display (see Chapter 4).

Checking Vertical Linearity

To check vertical linearity, follow these steps:

1. Place the right side of the reticle against the right edge of the bezel (see Figure D-3).
2. Count the number of rows between each etched line on the reticle. The numbers should be within ± 15 percent of each other (90 percent of one line).
3. If numbers of rows between each line etched on the reticel aren't equal, adjust the display.

INDEX

3

- 316X-style keyboard
 - assembly drawing, 7-17
 - cable removal/replacement, 2-7
 - PCB removal/replacement, 2-7
 - removal/replacement, 2-7
 - schematic, 7-7

A

- Adjustments
 - brightness, 4-14
 - centering rings, 4-11
 - display, 4-5
 - display leveling, 4-11
 - display magnets, 4-13
 - focus, 4-14
 - height, 4-11
 - linearity, 4-15
 - locations on terminal PCB, 4-10
 - vertical hold, 4-10
 - width, 4-11
- Alignment
 - display, 4-5
 - safety warning, 4-2
 - tools required, 4-2
- Amplifier for video, 6-8
- Anode
 - discharging before installation, 2-17
 - discharging before removal, 2-16
- Assembly drawings
 - 316X-style keyboard, 7-17
 - AT-style keyboard, 7-16
 - terminal PCB, 7-18
 - terminal PCB (logic), 7-18
 - WY-60 ASCII keyboard, 7-15
- AT-style keyboard
 - assembly drawing, 7-16
 - cable removal/replacement, 2-7
 - PCB removal/replacement, 2-7
 - removal/replacement, 2-7
 - schematic, 7-5

- Attribute control, 6-12
- Attribute data latch, 6-3
- Attributes of cursor, A-4
- AUX port
 - functional description, 6-11
 - test connector, C-1

B

- Back-to-back diagnostic test, 3-4, C-1
- Barrel distortion, D-2
- Beeper driver, 6-3
- Bezel, D-2
- Blanking
 - horizontal, 6-13
 - vertical, 6-13
- Blink rate generator, 6-3
- Block diagrams
 - keyboard, 6-8
 - monitor/power supply, 6-7
 - terminal PCB, 6-2
- Brightness
 - adjustment, 4-14
 - slideswitch, 1-5

C

- Cathode ray tube, see CRT
- Centering
 - checking with reticle, D-5
 - specifications, A-3
- Centering ring adjustment, 4-11
- Character
 - and attribute data RAM, 6-5
 - attributes, A-4
 - generation, 6-12
- Character row buffer data latch, 6-5
- Chip select decoder, 6-4
- Circuits
 - isolation jumpers, 3-15
 - regulating, 6-6
 - video clock, 6-11
- Cleaning; 1-6

Clock
 divider, 6-4
 generator, 6-3
 rates, 6-4
 UART, 6-6
Code ROM, 6-4
Communication interface,
 6-10
Component diagram
 316X keyboard PCB, 5-18
 AT-Style keyboard PCB,
 5-20
 power supply, 4-8
 terminal PCB, 5-14
 WY-60 keyboard PCB, 5-16
Computer interface, 3-13
Connector pin assignments,
 B-1
Continuity check, 3-14
Controller
 programmable video, 6-12
 programmable video timing,
 6-4
 video, 6-11
Controls
 attribute, 6-12
 soft font, 6-3
 user, 1-5
CRT
 display, 1-3, 6-13
 functional description,
 6-8
CRT/yoke assembly
 removing, 2-13
 replacing, 2-14
Cursor attributes, A-4

D
Data communication driver
 +12 volt, 6-8
 -12 volt, 6-8
Decoder, 6-4
Deflection circuit, 6-8
Diagnostic self-test
 back-to-back, 3-4
 connectors, 5-21
 procedure, 3-3
Dimensions
 keyboard, A-3
 screen, A-3
 terminal, A-3
Disable, 6-13
Discharging the anode, 2-16

Display
 adjustments, 4-1
 alignment, 4-1, 4-5
 alignment and adjustment
 tools, 4-2
 capacity, 1-3
 check with reticle, D-3
 definition, D-2
 format, A-1
 intensity, A-2
 leveling adjustment, 4-11
 memory, 6-11
 problems, 4-9
 size, A-2
 size of margins, 4-4
 specification, 4-2
 time, A-1
Display magnets
 adjustments, 4-13
 screen areas affected by,
 4-14
Dot clock oscillator, 6-5
Dot stretcher, 6-3
Drivers
 beeper, 6-3
 horizontal, 6-6
 video, 6-3

E
Environment, 3-13
Exploded views
 keyboard assemblies, 5-4
 terminal display assembly,
 5-3

F
Field, 6-13
Filter, line, 6-6
Flowchart for
 troubleshooting, 3-5
Flyback transformer, 6-8
Focus adjustment, 4-14
Font
 density, A-2
 RAM, 6-5, 6-12
Frequency, A-1
Functional descriptions
 attribute control, 6-12
 attribute data latch, 6-3
 AUX port, 6-11
 beeper driver, 6-3
 blink rate generator, 6-3

Functional descriptions

(continued)

- character and attribute data RAM, 6-5
- character row buffer data latch, 6-5
- chip select decoder, 6-4
- clock divider, 6-4
- clock generator, 6-3
- code ROM, 6-4
- communication interface, 6-10
- CRT, 6-8
- display memory, 6-11
- dot clock oscillator, 6-5
- dot stretcher, 6-3
- flyback transformer, 6-8
- font RAM, 6-5, 6-12
- gate array, 6-3
- horizontal driver, 6-6
- keyboard interface, 6-5, 6-11
- level converters (EIA to TTL), 6-5
- level converters (TTL to EIA), 6-5
- line filter, 6-6
- low order address latch, 6-4
- main switching power transformer, 6-6
- microcontroller, 6-9
- MODEM port, 6-10
- nonvolatile memory, 6-5, 6-11
- power supply voltage, 6-6
- presetable scan line counter, 6-3
- programmable video controller, 6-12
- programmable video timing, 6-4
- pulse width modulator, 6-6
- regulation circuitry, 6-6
- row buffer RAM, 6-5
- soft-font control, 6-3
- UART, 6-4
- UART clock, 6-6
- vertical deflection circuit, 6-8
- video amplifier, 6-8
- video clock circuits, 6-11
- video controller, 6-11
- video shift register, 6-3, 6-12
- voltage doubler, 6-6

Fuse

- domestic specifications, A-1
- international specifications, A-1
- removal/replacement, 2-10

G

- Gate array, 6-3
- Generator
 - blink rate, 6-3
 - character blink rate, 6-3
 - character clock, 6-3
 - cursor blink rate, 6-3

H

- Height
 - adjustment, 4-11
 - checking with reticle, D-4
- Horizontal
 - blanking, 6-13
 - driver, 6-6
 - font density, A-2

I

- I/O, see Input/output
- Input/output devices, 1-3
- Installation
 - keyboard, 1-5
 - terminal checklist, 3-12
- Interfaces
 - asynchronous, 1-3
 - AUX, 1-3
 - communication, 6-10
 - keyboard, 6-5, 6-11
 - MODEM, 1-3
 - primary, 1-3
 - RS-232C, 1-3
- Isolating circuits, 3-15

K

- Keyboard
 - 316X-style assembly
 - drawing, 7-17
 - 316X-style layout, 2-3
 - 316X-style schematic, 7-7
 - AT-style assembly drawing, 7-16
 - AT-style layout, 2-3
 - AT-style schematic, 7-5
 - block diagram, 6-8
 - checking, 3-15
 - description, 1-3
 - dimensions, A-3
 - installation, 1-5

Keyboard (continued)
 interface, 6-5, 6-11
 removal/replacement for
 316X-style, 2-7
 removal/replacement for
 AT-style, 2-7
 removal/replacement for
 WY-60 ASCII, 2-4
 WY-60 ASCII assembly
 drawing, 7-15
 WY-60 ASCII layout, 2-3
 WY-60 ASCII schematic, 7-3
 Keyboard cable removal and
 replacement
 316X-style, 2-7
 AT-style, 2-7
 WY-60 ASCII, 2-5
 Keyboard PCB
 component layout diagram,
 5-16, 5-18, 5-20
 components list, 5-4
 removal/replacement for
 316X-style, 2-7
 removal/replacement for
 AT-style, 2-7
 removal/replacement for
 WY-60 ASCII, 2-6

L
 Latch
 attribute data, 6-3
 character row buffer data,
 6-5
 low order address, 6-4
 Level converters
 EIA to TTL, 6-5
 TTL to EIA, 6-5
 Line attributes, A-4
 Line filter, 6-6
 Linearity
 adjustment, 4-15
 checking with reticle, D-5
 definition, D-2
 horizontal, A-3
 vertical, A-3
 Logic schematic
 terminal PCB, 7-9, 7-11
 Low order address latch, 6-4

M
 Main switching power
 transformer, 6-6
 Measurement direction, A-3

Memory
 display, 6-11
 nonvolatile, 6-5, 6-11
 pages, A-2
 terminal, 1-2
 Microcontroller
 8051, 6-3
 definition, 1-2
 functional description,
 6-9
 Modem, B-2
 MODEM port
 functional description,
 6-10
 test connector, C-1
 Modulator, pulse width,
 6-6
 Monitor/power supply
 schematic, 7-13

N
 Nonvolatile memory, 6-5,
 6-11

O
 Operating requirements, A-1
 Operator interfaces
 brightness slideswitch,
 1-5
 keyboard, 1-5
 power switch, 1-5
 setup parameters, 1-5
 Oscillator
 dot clock, 6-5

P
 Parts, 5-1
 Pin assignments, B-1
 Pincushion
 check with reticle, D-4
 distortion, D-2
 Ports
 8051 assignments, 6-9
 AUX, 6-11
 MODEM, 6-10
 pin assignments, B-1
 Power
 cord, 3-13
 requirements, A-1
 switch, 1-5
 Power on self-test, 3-3

Power supply
 +12 volt, 6-8
 +5 volt, 6-6
 -12 volt, 6-8
 component layout, 4-8
 voltage check, 3-14
 voltage functional description, 6-6

Presettable scan line counter, 6-3

Programmable video controller, 6-12

Programmable video timing, 6-4

Pulse width modulator, 6-6

Q

Quick reference guide for troubleshooting, 3-4

R

RAM
 character and attribute, 6-5
 font, 6-5
 row buffer, 6-5

Register, video shift, 6-3, 6-12

Regulation circuitry, 6-6

Removing
 ASCII keyboard cable, 2-5
 ASCII keyboard PCB, 2-6
 assemblies in the terminal module, 2-9
 CRT/yoke assembly, 2-13
 terminal enclosure, 2-9
 terminal PCB, 2-11
 WY-60 ASCII keyboard, 2-4
 yoke, 2-15

Replacing
 CRT/yoke assembly, 2-14
 fuse, 2-10
 terminal enclosure, 2-16
 terminal PCB, 2-13
 yoke, 2-16

Required tools
 alignment, 4-2
 removal and replacement, 2-3

Requirements
 operating, A-1
 power, A-1

Resolution, A-1

Reticle
 checking centering, D-5
 checking height, D-4
 checking linearity, D-5
 checking pincushioning, D-4
 checking straightness, D-4
 checking width, D-3

Retrace time, A-1

Row buffer RAM, 6-5

S

Safety warnings, 2-2, 3-1, 4-2

Scan frequency, A-1

Scan line
 definition, 6-13
 presettable counter, 6-3

Schematics
 316X-style keyboard, 7-7
 AT-style keyboard, 7-5
 terminal PCB (logic), 7-9, 7-11
 terminal PCB (monitor and power supply), 7-13
 WY-60 ASCII keyboard, 7-3

Screen dimensions, A-3

Self-tests
 back-to-back diagnostic, 3-4
 diagnostic, 3-3
 power-on, 3-3

Setup parameters, 1-5

Shipping weight, A-3

Soft-font control, 6-3

Spare parts, 5-1

Specifications
 display, 4-2
 display margins, 4-4
 terminal, A-1

Straightness check, D-4

T

Terminal
 adjustments, 4-1
 cleaning, 1-6
 control, 1-3
 description, 1-2
 dimensions, A-3
 display assembly list, 5-3
 installation checklist, 3-12
 preparation for reticle procedure, D-2
 specifications, A-1

Terminal enclosure
 removing, 2-9
 replacing, 2-16
Terminal PCB
 assembly drawing, 7-18
 component adjustment
 locations, 4-10
 component layout diagram,
 5-14
 logic schematic, 7-9, 7-11
 removing, 2-11
 replacing, 2-13
 schematic, 7-13
Test connectors
 AUX port, C-1
 back-to-back, C-1
 MODEM port, C-1
Test patterns, 4-15
 character attribute, 4-15
 M, 4-15
 O, 4-16
Tools required
 for alignment, 4-2
 for assembly
 removal/replacement, 2-3
 for power supply check,
 3-14
Transformer
 flyback, 6-8
 main switching power, 6-6
Troubleshooting
 aids, 3-12
 flowchart, 3-5
 quick reference guide, 3-4
 safety warning, 3-1
 symptoms, 3-4
 tools required, 3-1

U

UART, 6-4
UART clock, 6-6

V

Vertical
 blanking, 6-13
 deflection circuit, 6-8
 font density, A-2
 hold adjustment, 4-10
Video
 amplifier, 6-8
 controller, 6-11
 display alignment pattern,
 D-2
 inspection reticle, D-1
 shift register, 6-3

Video clock circuits, 6-11
Video shift register, 6-12
Voltage doubler, 6-6
Voltages
 checking, 3-14
 power supply, 3-14, 6-6
 specifications, A-1

W

Warmup time, A-3
Weight, A-3
Width
 adjustment, 4-11
 checking with reticle, D-3
WY-60 ASCII keyboard
 assembly drawing, 7-15
 cable removal/replacement,
 2-5
 PCB removal/replacement,
 2-6
 schematic, 7-3

Y

Yoke
 removing, 2-15
 replacing, 2-16